

# Electrical & Computer

# FE

Technical Study Guide  
& Full Exam



Learn the key concepts and skills necessary to pass the FE Exam



**Engineering**  
Pro Guides

by **Justin Kauwale, P.E.**

# Electrical & Computer FE Technical Study Guide & Full Exam How to Pass the FE Electrical & Computer Exam

## Table of Contents

Section 0.0 .....	Introduction
Section 1.0 .....	Mathematics
Section 2.0 .....	Probability & Statistics
Section 3.0 .....	Ethics & Professional Practice
Section 4.0 .....	Engineering Economics
Section 5.0 .....	Properties of Electrical Materials
Section 6.0 .....	Engineering Sciences
Section 7.0 .....	Circuit Analysis
Section 8.0 .....	Linear Systems
Section 9.0 .....	Signal Processing
Section 10.0 .....	Electronics
Section 11.0 .....	Power
Section 12.0 .....	Electromagnetics
Section 13.0 .....	Control Systems
Section 14.0 .....	Communications
Section 15.0 .....	Computer Networks
Section 16.0 .....	Digital Systems
Section 17.0 .....	Computer Systems
Section 18.0 .....	Software Development
Section 19.0 .....	Full Exam

# 0 - Introduction

---

How to Study for and Pass the FE Exam



# Section 0.0 - Introduction

## Table of Contents

1.0 Introduction .....	2
1.1 Exam Format.....	2
1.2 Key Concepts and Skills.....	3
1.2 Units .....	5
2.0 Disclaimer .....	5
3.0 How to use this Book .....	5
4.0 Practice exam tips.....	6
5.0 NCEES FE Reference Handbook .....	9
5.1 Unit Conversion.....	9
5.2 Tables and Graphs.....	9
6.0 Past Exams .....	10
6.1 Pass Rates on Survey vs. NCEES .....	10
6.2 Estimated Cut Score.....	10



# 1.0 INTRODUCTION

One of the most important steps in an engineer's career is obtaining the professional engineering (P.E.) license. It allows an individual to legally practice engineering in the state of licensure. This credential can also help to obtain higher compensation and develop a credible reputation. The first step towards obtaining your P.E. is passing the Fundamentals of Engineering (F.E.) Exam. Both tests are administered by the National Council of Examiners for Engineering and Surveying (NCEES). The FE Exam is a year round computer based test that can be taken as early as your senior year in college or with at least 3 years of engineering-related work experience. Once passed, the FE Exam will certify you as an Engineering in Training (EIT). With enough experience after passing the EIT, you will become eligible for the PE Exam. Engineering Pro Guides focuses on helping engineers pass the NCEES exam through the use of free content on the website, <http://www.engproguides.com> and through the creation of books like sample exams and guides that outline how to pass the PE exam.

In the FE exam you will not be able to bring in any outside reference material. You will be given the *NCEES FE Exam Reference Handbook*, which contains all the necessary equations, tables, and graphs that you will need to solve each problem. The *NCEES FE Exam Reference Handbook* will be provided as a searchable electronic pdf during the test. The key to passing the FE exam is understanding the key concepts and skills that are tested on the exam and becoming familiar with using this handbook to solve each problems in approximately 2-3 minutes. Although the NCEES handbook provides the necessary equations for the exam, knowing how to apply them and which equations to use requires an understanding of the concepts and practice of the skills. The FE Exam is available for 6 disciplines plus a generic engineering discipline. This technical guide teaches you the key concepts and skills required to pass the Electrical F.E. Exam in a single document.

## 1.1 EXAM FORMAT

### *How is the exam formatted?*

The FE exam format and additional exam day information can be found on the NCEES Examinee Guide (<https://ncees.org/exams/examinee-guide/>). The entire exam period is about 6 hours, with 2 minutes for signing agreements, 8 minutes for tutorials, and one break up to 25 minutes. You will have a total of 5 hours 20 minutes of actual exam time to solve 110 problems, which equates to about 2.9 minutes per problem if spread out evenly. The test is broken up into two sessions. The length of each session is determined by the number of problems, 55 problems per session, and not the time. So, you could spend more or less than half the time on the first session, and the remaining 5 hours 20 minutes will be allotted for the second session. Since the first session doesn't have a halfway time limit, it is very important to keep watch of the clock to make sure you have enough time for the second session. Before each session is completed, you are allowed to go back to problems that you may have skipped or want to check in that session. However, once the first session is completed and submitted, you are no longer allowed to revisit the questions in that session. There is a 25 minute break in between the sessions. You are allowed to take less than a 25 minute break or no break at all, but this does not increase the time you have to answer

exam questions. No points are deducted for incorrect answers, so be sure to provide an answer for all questions, even if it is a guess. The final results are scaled based on the exam difficulty. There are five types of question formats that could be presented on the exam.

1. Multiple Choice (4 choices) – Select one option, *majority of questions in the exam*
2. Multiple Answers – Select multiple answers that are correct
3. Select by Clicking – Click on a point on a graph, etc
4. Drag and Drop – Matching, sorting, labeling, etc
5. Fill in the Blank – Type in the answer

The types of questions and number of questions per topic will be based on the outline provided by NCEES, discussed in the next section. These topics will not be labeled on the test. Finally, the NCEES Examinee Guide states that there will be some questions that will not be scored in the exam. These are questions that are tested for their quality and possible use in future exams. Your final results will be given to you 7-10 days after you take the exam.

## 1.2 KEY CONCEPTS AND SKILLS

### *How are the key concepts and skills determined?*

The key concepts and skills tested in the sample exams and taught in this technical study guide were first developed through an analysis of the topics and information presented by NCEES. The above factors related to timing is considered. The Electrical FE exam will focus on the following topics as indicated by NCEES. (<https://ncees.org/engineering/fe/>):

- 1 Mathematics - (11-17 questions)
- 2 Probability and Statistics - (4-6 questions)
- 3 Ethics and Professional Practice - (3-5 questions)
- 4 Engineering Economics - (3-5 questions)
- 5 Properties of Electrical Materials - (4-6 questions)
- 6 Engineering Sciences - (6-9 questions)
- 7 Circuit Analysis - (10-15 questions)
- 8 Linear Systems – (5-8 questions)
- 9 Signal Processing - (5-8 questions)
- 10 Electronics - (7-11 questions)
- 11 Power - (8-12 questions)
- 12 Electromagnetics - (5-8 questions)
- 13 Control Systems - (6-9 questions)
- 14 Communications - (5-8 questions)
- 15 Computer Networks - (3-5 questions)
- 16 Digital Systems - (7-11 questions)
- 17 Computer Systems - (4-6 questions)
- 18 Software Development - (4-6 questions)

Each of these broad topics were investigated and filtered for concepts and skills that met the following criteria:

**(1) First, the concept and skill must be fundamental principles taught in college.** The test is intended for the engineer right out of college without work or practical experience. The exam will focus on fundamental engineering principles you will need during your career. However, since the Electrical Engineering discipline is broad, the exam will be based on the general knowledge that each Electrical Engineer develops in school and will not include an in-depth, higher level analysis of a specific topic. The subjects listed above are the basic curriculum that Electrical Engineers should encounter before they graduate.

**(2) Second, the skill and concept must be testable in roughly 2.9 minutes per problem.** There are (110) questions on the Electrical FE exam and you will be provided with 5 hours 20 minutes to complete the exam. This results in an average of 2.9 minutes per problem. This criterion limits the complexity of the exam problems and the resulting solutions. For example, voltage drop calculations are common in Circuits, but the calculations can get lengthy depending on the complexity of the circuit. Thus, simple circuits will be used during the exam.

**(3) Third, the information and equations required to solve the problems should be in the NCEES FE Reference Handbook.** Since you are not allowed to bring in outside resource, the Handbook and along with any information given to you in the problem should provide you with sufficient information needed to solve the problems. It is extremely unlikely that you will need an equation that is not given to you in the reference handbook. Thus, the handbook is an additional resource for understanding the types of questions that could be asked. Note that the *NCEES FE Reference Handbook* contains extraneous information for the Electrical FE exam, since the same resource is used across all tested disciplines. To narrow down the relevant topics, the handbook was cross referenced with the NCEES Electrical FE outline mentioned in the last section. Lastly, the solution may still require a variation of the equations in the reference handbook. Therefore it is very important to understand how to use these equations, as well as the variables and the units that the equations require.

**(4) The F.E. Exam tests the background engineering concepts and skills for a practicing Electrical Engineer and not the derivation of the topic or concept.** The exam is intended to prove that the test taker is minimally competent to practice as an engineer in training and has the basic understanding of Electrical Engineering principles. This background knowledge is necessary for the practicing engineer to understand how engineering concepts and skills are applied in the field. Therefore, the exam is less concerned with theory and more with how these concepts and skills can be applied. For example, the F.E. exam is less interested with the derivation of angular momentum equations and more with how to solve for resultant forces or final velocity conditions.

In summary, this book is intended to teach the necessary skills and concepts to develop a minimally competent, practicing Electrical Engineer in Training, capable of passing the F.E. exam. This book and the sample exam do this through the following means:

- (1) Teaching common skills, principles, and concepts in the Electrical field.**
- (2) Providing sample problems that can be completed in roughly 2-3 minutes per problem.**
- (3) Teaching how to use and apply the equations in the *NCEES FE Reference Handbook*.**

#### **(4) Teaching the application of the skill and concept for an engineer in training.**

## 1.2 UNITS

The units that are used in the F.E. Exam are the International System of Units (SI) and the United States Customary System Units (USCS). The equations in the *NCEES FE Reference Handbook* are more generic and does not necessarily differentiate between SI or USCS units. Therefore, it is very important, especially with the USCS problems, to make sure all necessary conversion factors are used and that the units cancel out to the unit of your desired final answer.

## 2.0 DISCLAIMER

In no event will Engineering Pro Guides be liable for any incidental, indirect, consequential, punitive or special damages of any kind, or any other damages whatsoever, including, without limitation, those resulting from loss of profit, loss of contracts, loss of reputation, goodwill, data, information, income, anticipated savings or business relationships, whether or not Engineering Pro Guides has been advised of the possibility of such damage, arising out of or in connection with the use of this document or any referenced documents and/or websites.

This book was created on the basis of determining an independent interpretation of the minimum required knowledge and skills of an engineer in training. In no way does this document represent the National Council of Examiners for Engineers and Surveying views or the views of any other professional engineering society.

## 3.0 HOW TO USE THIS BOOK

This book is organized into the topics as designated by the NCEES. These topics include:

- Section 0.0: Introduction
- Section 1.0: Mathematics
- Section 2.0: Probability and Statistics
- Section 3.0: Ethics and Professional Practice
- Section 4.0: Engineering Economics
- Section 5.0: Properties of Electrical Materials
- Section 6.0: Engineering Sciences
- Section 7.0: Circuit Analysis (DC and AC Steady State)
- Section 8.0: Linear Systems
- Section 9.0: Signal Processing
- Section 10.0: Electronics
- Section 11.0: Power
- Section 12.0: Electromagnetics



- Section 13.0: Control Systems
- Section 14.0: Communications
- Section 15.0: Computer Networks
- Section 16.0: Digital Systems
- Section 17.0: Computer Systems
- Section 18.0: Software Development
- Section 19.0: Full Exam

First, it is recommended that the engineer in training download the *NCEES FE Reference Handbook* from your myNCEES account.

Second, proceed through the book in the order designated. Go through and first read the material of the section, then complete the practice problems designated for that section. If you have trouble with the practice problems, review the material and then read the solutions. These problems are meant to practice the application of the skill or concept presented in the section. The problems are exam difficulty level.

Finally, set aside a five-hour twenty-minute block of uninterrupted time to complete the full exam. Gather your references and calculator and create a test-like environment. Set a timer and proceed to take the sample exam, which can be purchased separately. Remember that the exam is only 55 problems each for the first and second sessions and does not encompass all the possible items that can appear on an exam, but it should give you an idea of your level of readiness for the exam.

## 4.0 PRACTICE EXAM TIPS

Engineering Pro Guides practice exam problems can be used in multiple ways, depending on where you are in your study process. If you are at the beginning or middle, it can be used to test your competency, gain an understanding and feel for the test format, and help to highlight target areas to study. If you are at the end, it can be used to determine your preparedness for the real exam. Remember that the questions are a sample of the many topics that may be tested and are limited to fit a full exam length and therefore is not comprehensive of all concepts. Also the practice exam problems are split up throughout the entire book.

Because the exam is written to be similar to the difficulty and format of the NCEES exam, it is recommended that the test be completed in one sitting and timed for two hours forty minutes to simulate half of the real exam. This will give you a better indication of your status of preparation for the exam. If you are at the ending of your studying, it is recommended to couple this exam with the second section to simulate the full exam test day.

Review the exam day rules and replicate the environment for the real test as much as possible, including the type of calculator you may use and the acceptable references. Keep a watch or clock next to you to gauge your pace for 55 questions in 2 hours 40 minutes.

Based on the NCEES website, the following are general rules for exam day.

Allowed:

1. ID used for admission
2. Approved calculator (2 recommended for backup. The backup will be stored with your personal items)
3. Eyeglasses
4. Light sweater or jacket
5. Test center locker key
6. Test center provided booklet and marker
7. Test center comfort aids, approved upon visual inspection. See the *Pearson VUE Comfort Aid List* on the Pearson VUE website (includes medicine – inhaler, aspirin not in bottle, eye drops, cough drops, etc and mobility devices – crutches, wheelchairs, etc. Tissues and earplugs must be provided by the test center.)
8. Religious head coverings

Prohibited:

1. Cell phones
2. Electronic Devices (other than approved calculator)
3. Watches
4. Wallets and Purses
5. Hats and hoods
6. Bags
7. Coats
8. Books
9. Pens, Pencils, Erasers
10. Food, Drinks
11. Weapons
12. Tobacco
13. Eyeglass cases
14. Scratch Paper (all writing devices are provided)

Most test centers will have lockers for you to store your personal items. For additional references on exam day policies, exam day processes, and items to bring on your exam day, review the NCEES Examinee Guide:

<http://ncees.org/exams/examinee-guide/>

For best use of your time, answer the questions that you know first and return to the questions that you are unfamiliar with later. On the computer based test, you are able to bookmark the answers you may want to come back to later. Once all the known questions are answered, go through the test again and attempt to answer the remaining questions by level of difficulty. If time allots, review your answers.

If you are stuck on a question, seek the following avenues.

1. *NCEES FE Reference Handbook*: It is important to understand the *NCEES FE Reference Handbook*. During times of uncertainty, this will likely lead you to your answers. Determine the key concept that is being asked in the question and refer to this reference book. Remember that the reference is searchable, so you will be able to do a search by keyword (Ctrl+F). Additional tips on this resource are discussed in the next section.
2. Process of Elimination: In most questions, there are only four possible choices for each question. Ask yourself if there is an answer that does not make sense and eliminate it. Further narrow down the answer that are derived from equations or concepts that you know are not right and are instead meant to deceive the test taker. See if there are answers that are similar or separated by something like a conversion error. This may be an indication that the correct equation was used.
3. Educated Guess: Remember that there is no penalty for wrong answers. Hopefully with the process of elimination you are able to narrow down as many answers as possible and are able to create an educated guess.
4. If the time is almost up and there are still unanswered questions remaining, determine whether it makes sense to check for mistakes on the problems you do know how to solve, or to tackle the unanswered problems.

#### Typical Exam Verbiage/Design:

1. Most Nearly: Due to rounding differences, the exam answers may not match yours exactly and in fact may not even closely resemble your answer. NCEES uses the term “most nearly” to test your confidence in your solution. When the question prompts you with “most nearly”, choose the answer that most closely matches yours, whether it be greater than or lesser to your value.
2. Irrelevant Information: The exam is intended to test your overall understanding of concepts. At times the question will include unnecessary information that is meant to misdirect you.
3. Deceiving Answers: NCEES wants to know that you are able to determine the appropriate methods for the solutions. There are answers that were intentionally produced from wrong equations to mislead the test taker. For example, you may forget a 1/2 in the formula,  $KE = (1/2)MV^2$  and there would be two answers each off by a factor of 1/2.
4. Do Not Overanalyze: The exam questions are meant to be completed in less than 3 minutes. Therefore, they are intended to be written as straight forward as possible. Do not be tempted to overanalyze the meaning of a question. This will only lead you down the wrong path.

Review the Solutions:

Once the sample test is completed, grade your results. Measure your aptitude in speed, concept comprehension, and overall score. If your score is above the 75% range then you are in good shape. This 75% score is only applicable if you have prepared completely for the exam. If you are just starting out, then do not be worried about a low score. This number is also just a range; there is no finite score to determine passing the test. Instead, NCEES calibrates the results against practicing professional engineers. See this page <http://ncees.org/exams/scoring-process/> for a better understanding of how NCEES grades the scores.

Review the answers that you got wrong and use the solutions as a learning tool on how to address these types of problems. Compare the types of questions you are missing with the NCEES outline of topics and determine where you should focus your studying. Finally repeat as many practice problems as you can to get a better grasp of the test and to continually improve your score.

## 5.0 NCEES FE REFERENCE HANDBOOK

As previously mentioned, the *NCEES FE Reference Handbook* is the only reference material you will have during the exam. Therefore, it is very important to use this reference book when doing practice problems. You should become familiar with the layout of the book, how to apply the equations, what the variables mean, what units the equations are in, and where to find common constants, tables, and graphs. The *NCEES FE Reference Handbook* can be purchased as a hardcopy on the NCEES website or downloaded a free pdf of the latest version from your *MyNCEES* account. I would recommend studying from the pdf to become familiar with using the reference book electronically with the search (Ctrl+F) options. The index will not be provided during the real exam. When studying, notice how the Handbook is organized and how it is broken out by subject, then by discipline. Take some time to go browse through the entire reference handbook to see where different equations are located. Realize that some of the Electrical FE questions may overlap with other disciplines, like Civil and Mechanical.

### 5.1 UNIT CONVERSION

The first section of the *NCEES FE Reference Handbook* has a list of typical unit conversions as well as common constants, such as the universal gas constant, gravity, electron charge constant.

### 5.2 TABLES AND GRAPHS

It is important to be able to quickly navigate through the *NCEES FE Reference Handbook* and know where the common tables are used across multiple subjects.

The following are examples of common tables or graphs that you should be aware of.

- Derivative & Integral Tables – *Mathematics*

- Trigonometric Identities – *Mathematics*
- Fourier Transform Pairs & Theorems – *Mathematics*
- Laplace Transform Pairs & Theorems – *Mathematics*
- Probability Distribution Tables – *Probability & Statistics*
- Periodic Table – *Chemistry*
- Metal Properties – *Materials Science/Structure of Matter*
- Factor Tables – *Engineering Economics*
- Z-Transform Table – *Electrical & Computer Engineering*
- Convolution Table – *Electrical & Computer Engineering*

## 6.0 PAST EXAMS

### 6.1 PASS RATES ON SURVEY VS. NCEES

The NCEES website indicates that 67% of Electrical FE test takers pass the exam. These pass rates only include first time test takers that have attended an accredited engineering program and took the test within 12 months of graduation.

### 6.2 ESTIMATED CUT SCORE

Since the exam is weighted, the cut score is not clearly defined and is never posted by NCEES. The general online consensus is that the passing rate is about 50-55% correct. Our goal with this book is to get you to a score of at least 70%. You should be able to obtain at least this amount to increase your confidence of passing.

# 1 - Mathematics

---

Algebra and trigonometry, Complex numbers, Discrete mathematics, Analytic geometry, Calculus, Differential equations, Linear algebra, Vector analysis



# Section 1.0 – Mathematics

## Table of Contents

1.0	Introduction .....	3
2.0	Algebra & Trigonometry .....	3
2.1	Arithmetic.....	3
2.2	Exponents.....	4
2.3	Logarithmic Equations .....	4
2.4	Natural Logarithmic Equations .....	5
2.5	Trigonometry .....	6
2.5.1	Right Angle Equations.....	6
2.5.2	Law of Sines & Cosines Equations .....	6
2.5.3	Trigonometric Identities .....	7
3.0	Complex Numbers .....	7
4.0	Discrete Mathematics.....	8
4.1	Set Theory .....	9
5.0	Analytic Geometry.....	11
5.1	Find Line Equation Given Two Points .....	11
5.2	Parallel and Perpendicular Lines.....	12
5.3	Distance Between Two Points.....	13
6.0	Calculus .....	14
6.1	Derivatives.....	14
6.2	Integrals.....	15
7.0	Differential Equations .....	15
8.0	Linear Algebra.....	16
8.1	Linear Equations.....	16
8.2	Matrices .....	16
9.0	Vector Analysis .....	18
9.1	Rectangular Form.....	19
9.2	Polar Form.....	20
9.3	Converting Polar and Rectangular Forms - Calculator.....	20
9.4	Vector Mathematical Operations .....	22
10.0	Practice Exam Problems.....	25
10.1	Practice Problem 1 – Calculus .....	25



10.2	Practice Problem 2 – Calculus .....	25
10.3	Practice Problem 3 - Calculus .....	26
10.4	Practice Problem 4 – Calculus .....	26
10.5	Practice Problem 5 – Calculus .....	27
10.6	Practice Problem 6 – Calculus .....	27
10.7	Practice Problem 7 – Algebra .....	28
10.8	Practice Problem 8 – Trigonometry .....	28
10.9	Practice Problem 9 – Complex Numbers .....	29
10.10	Practice Problem 10 – Complex Numbers .....	29
10.11	Practice Problem 11 – Discrete Mathematics .....	30
10.12	Practice Problem 12 – Analytic Geometry .....	30
10.13	Practice Problem 13 – Vector Analysis .....	31
11.0	Practice Exam Solutions .....	32
11.1	Solution 1 – Calculus .....	32
11.2	Solution 2 – Calculus .....	32
11.3	Solution 3 - Calculus .....	32
11.4	Solution 4 - Calculus .....	33
11.5	Solution 5 - Calculus .....	34
11.6	Solution 6 - Calculus .....	34
11.7	Solution 7 - Algebra .....	34
11.8	Solution 8 – Trigonometry .....	35
11.9	Solution 9 – Complex Numbers .....	36
11.10	Solution 10 – Complex Numbers .....	36
11.11	Solution 11 - Discrete Mathematics .....	36
11.12	Solution 12 - Analytic Geometry .....	37
11.13	Solution 13 - Vector Analysis .....	38





## 1.0 INTRODUCTION

Mathematics accounts for approximately 11 to 17 questions on the Electrical FE exam. The topics covered in this section include Analytic Geometry, Calculus, Linear Algebra, Vector Analysis, Differential Equations and Numerical Methods. At first glance, these topics seem vast and daunting, but you should not be worried. You will most likely only need to know the equations that are shown in the NCEES FE Reference Handbook, as they relate to Electrical Engineering.

Section 1.0 Mathematics (11 to 17 Problems)		
NCEES Outline Value	Engineering Pro Guides	
	Section 1.0	Introduction
1A	Section 2.0	Algebra & Trigonometry
1B	Section 3.0	Complex Numbers
1C	Section 4.0	Discrete Mathematics
1D	Section 5.0	Analytic Geometry
1E	Section 6.0	Calculus
1F	Section 7.0	Differential Equations
1G	Section 8.0	Linear Algebra
1H	Section 9.0	Vector Analysis
	Section 10.0	Practice Exam Problems

## 2.0 ALGEBRA & TRIGONOMETRY

This section is designed to refresh your memory on the basic algebra and trigonometry skills that you should know for the FE exam. Many of the formulas and equations discussed in this section are in the FE Reference Handbook, but the key is to know how to use those formulas and equations.

### 2.1 ARITHMETIC

These arithmetic properties are useful to remember and are not explicitly shown in the FE Reference Handbook.

$$\text{Associative Law} \rightarrow x * (yz) = (xy) * z$$

$$\text{Commutative Law} \rightarrow x + y = y + x$$

$$\text{Distributive Law} \rightarrow x * (y + z) = xy + xz$$

## 2.2 EXPONENTS

These exponent properties are useful to remember and are not explicitly shown in the FE Reference Handbook.

$$x^a * x^b = x^{a+b}; \quad \frac{x^a}{x^b} = x^{a-b}; \quad \frac{1}{x^b} = x^{-b}$$

$$(x^a)^b = x^{a*b}; \quad x^{\frac{a}{b}} = (x^a)^{\frac{1}{b}}$$

$$(x * y)^a = x^a * y^a; \quad x^0 = 1$$

## 2.3 LOGARITHMIC EQUATIONS

Logarithmic equations are used in engineering to describe situations where one variable changes exponentially when compared to another. Logarithmic equations are shown as having the following relationship between exponential functions.

$$\text{Log}_{\text{base}}(x) = y; \text{ Base}^y = x$$

The most important bases are “10” and “e”. The term “e” will be described in the next topic under natural logarithms. If a log function does not have a base specified then you can assume that the base is “10”. The following table shows the result of taking the log of various values of “x”.

x	x (scientific)	y = LOG(x)
0	0.E+00	N/A
1	1.E+00	0
10	1.E+01	1
100	1.E+02	2
1,000	1.E+03	3
100,000	1.E+05	5
1,000,000	1.E+06	6
10,000,000	1.E+07	7
100,000,000	1.E+08	8
1,000,000,000	1.E+09	9
10,000,000,000	1.E+10	10

The following graph plots “y = log(x)”. It shows that as “x” gets closer to 0, the y value approaches a very large negative number. As “x” increases the value of “y” increases slowly. As you can see from the previous table, the difference between each x value gets increasingly large, while the difference between each y value is only 1.

# 2 – Probability & Statistics

---

Measures of central tendencies and dispersions (e.g., mean, mode, standard deviation), Probability distributions (e.g., discrete, continuous, normal, binomial) Expected value (weighted average) in decision making, Estimation for a single mean (e.g., point, confidence intervals, conditional probability)



## Section 2.0 – Probability and Statistics

### Table of Contents

1.0	Introduction .....	2
2.0	Measures of Central Tendencies and Dispersions .....	2
2.1	Mean or Average .....	2
2.2	Mode.....	3
2.3	Median.....	3
2.4	Geometric Mean .....	3
2.5	Standard Deviation .....	3
3.0	Probability Distributions.....	4
3.1	Binomial Distribution.....	4
3.2	Normal Distribution .....	5
3.3	T-Distribution .....	8
3.4	$\chi^2$ -Distribution .....	10
4.0	Expected Value .....	10
5.0	Estimation for a Single Mean .....	11
6.0	Practice Exam Problems.....	12
6.1	Practice Problem 1 – Binomial Distribution .....	12
6.2	Practice Problem 2 – Standard Deviation.....	12
6.3	Practice Problem 3 – Probability Distribution.....	13
6.4	Practice Problem 4 – Geometric Mean.....	13
6.5	Practice Problem 5 – Statistics.....	14
6.6	Practice Problem 6 – Normal Distribution.....	14
7.0	Practice Exam Solutions .....	15
7.1	Solution 1 – Binomial Distribution .....	15
7.2	Solution 2 – Standard Deviation .....	15
7.3	Solution 3 – Probability Distribution.....	16
7.4	Solution 4 – Geometric Mean .....	16
7.5	Solution 5 - Statistics .....	17
7.6	Solution 6 – Normal Distribution .....	17



## 1.0 INTRODUCTION

The Probability and Statistics section accounts for approximately 4 to 6 questions on the Electrical FE exam. Statistics is primarily used in the electrical and computer engineering fields for data analysis and prediction, reliability, i.e. failure rates, and statistical quality control. This section focuses on the following NCEES Outline topics, Measures of Central Tendencies and Dispersions, Probability Distributions, Expected Value and Estimation for a Single Mean.

Probability Distribution involves applying a mathematical formula to describe the probability of a measured or recorded variable occurring at a certain value. This is useful for characterizing the measured output of any electrical or computer system property when you are taking a sample of a larger number. For example, when you measure 100 points, this is only a sample of an infinite amount of points that could have been recorded. A probability distribution will help to characterize the data with the limited 100 measurements that were made.

Expected Value uses weighted averages of each value to produce the most likely value.

Section 2.0 Probability and Statistics (4 to 6 Problems)		
NCEES Outline Value	Engineering Pro Guides	
	Section 1.0	Introduction
2A	Section 2.0	Measures of Central Tendencies and Dispersions
2B	Section 3.0	Probability Distributions
2C	Section 4.0	Expected Value
2D	Section 5.0	Estimation for a Single Mean
	Section 6.0	Practice Exam Problems

## 2.0 MEASURES OF CENTRAL TENDENCIES AND DISPERSIONS

Before you get to probability distributions, you need to understand some of the basic topics in probability like the difference between samples and population, mean, mode, standard deviation. As you go through these topics, you should remember that probability is used in mechanical engineering to measure the reliability of a set of data points.

### 2.1 MEAN OR AVERAGE

The mean of a set of data points is calculated by summing up all the values and dividing by the total number of data points. The mean is also known as the average.

$$\bar{x} = \frac{\sum_1^n x_i}{n}$$

*n = number of data points;  $x_i$  = measured value;  $\bar{x}$  = mean or average*

# 3 – Ethics & Professional Practice

---

Codes of ethics (professional and technical societies), NCEES Model Law and Model Rules, Intellectual property (e.g., copyright, trade secrets, patents)



# Section 3.0 – Ethics and Professional Practice

## Table of Contents

1.0	Introduction .....	1
2.0	Practice Exam Problems.....	3
2.1	Practice Problem 1 – Codes of Ethics .....	3
2.2	Practice Problem 2 – Agreements and Contracts.....	3
2.3	Practice Problem 3 – Ethical and Legal Considerations.....	4
2.4	Practice Problem 4 – Professional Liability .....	4
2.5	Practice Problem 5 – Public, Health, Safety & Welfare .....	4
3.0	Practice Exam Solutions .....	5
3.1	Solution 1 – Codes of Ethics .....	5
3.2	Solution 2 – Agreements and Contracts .....	5
3.3	Solution 3 – Ethical and Legal Considerations .....	5
3.4	Solution 4 – Professional Liability .....	6
3.5	Solution 5 – Public, Health, Safety & Welfare .....	6

## 1.0 INTRODUCTION

The Ethics and Professional Practice section accounts for approximately 3 to 5 questions on the Electrical and Computer FE exam. The NCEES outline provides the following topics on its outline, Codes of Ethics, NCEES Model Law and Model Rules and Intellectual Property.

Section 3.0 Ethics and Professional Practice (4 to 6 Problems)		
NCEES Outline Value	Engineering Pro Guides	
	Section 1.0	Introduction
3A	Section 1.0	Codes of Ethics (professional and technical societies)
3B	Section 1.0	NCEES Model Law and Model Rules
3C	Section 1.0	Intellectual Property (e.g., copyright, trade secrets, patents)
	Section 2.0	Practice Exam Problems

There are a few things that you can do to prepare for these problems.

(1) The first can be found in the *NCEES FE Reference Handbook*. There are about 8 pages on Ethics. This section covers the Codes of Ethics, Intellectual Property and the NCEES Model Law and Model Rules.

(2) The second is to read through the Model Law. The model law is published by NCEES and it is on the NCEES website. The link is shown below. The model law has very general regulations to govern engineering for the purposes of keeping the public safe. It is important to note that these laws are only ideas and it is up to each authority having jurisdiction like your State board to come up with their own laws.

NCEES Publications Website: <https://ncees.org/about/publications/>

Model Law Website: [https://ncees.org/wp-content/uploads/Model\\_Law\\_2018.pdf](https://ncees.org/wp-content/uploads/Model_Law_2018.pdf)

(3) You should also read through the Model rules. The model rules are published by NCEES and it is on the NCEES website. The link is shown below. The model rules complement the model laws. One key section in the model rules is the Rules of Professional Conduct.

Model Rules Website: [https://ncees.org/wp-content/uploads/Model\\_Law\\_2018.pdf](https://ncees.org/wp-content/uploads/Model_Law_2018.pdf)

Once you have read through these two writings, the following practice problems will help you to become familiar with the problems that may appear on the exam.

(4) This final task is optional, because the first three tasks should give you enough preparation for these 4-6 problems. The National Society of Professional Engineers or NSPE has information on a lot of legal cases and can provide insight on the topic of ethics and professional practice. The following link has a list of Ethics Resources. You should read the NSPE Ethics Reference Guide.

NSPE Ethics Resources:

<https://www.nspe.org/resources/ethics/ethics-resources/other-ethics-resources>

NSPE Ethics Reference Guide:

<https://www.nspe.org/sites/default/files/resources/pdfs/Ethics/CodeofEthics/NSPECodeofEthicsforEngineers.pdf>





# 4 – Engineering Economics

---

Time value of money (e.g., present value, future value, annuities), Cost estimation, Risk identification, Analysis (e.g., cost-benefit, trade-off, breakeven)



# Section 4.0 – Engineering Economics

## Table of Contents

1.0	Introduction .....	2
2.0	Time Value of Money .....	2
2.1	Future and Present Value .....	2
2.2	Annual Value or Annuities .....	3
3.0	Economic Analyses .....	5
3.1	Convert to Present Value .....	6
3.2	Convert to Future Value .....	7
3.3	Convert to Annualized Value .....	7
3.4	Factor Tables.....	8
3.5	Convert to Rate of Return.....	10
3.6	Break Even Analysis.....	11
3.7	Simple Payback.....	11
4.0	Cost, Including Incremental, Average, Sunk & Estimating .....	11
4.1	Average Costs .....	11
4.2	Incremental Costs.....	12
4.3	Sunk Costs .....	12
4.4	Estimating Costs.....	12
4.4.1	Cost Indexes .....	13
4.4.2	Capital Cost Estimation .....	13
4.4.3	Equipment Scaling Cost .....	14
5.0	Depreciation .....	14
5.1	Straight Line .....	14
5.2	Modified Accelerated Cost Recovery System (MACRS).....	15
6.0	Practice Exam Problems .....	17
6.1	Practice Problem 1 – Annual Value .....	17
6.2	Practice Problem 2 – Present Value.....	17
6.3	Practice Problem 3 – Rate of Return .....	18
6.4	Practice Problem 4 – Simple Payback .....	18
6.5	Practice Problem 5 – Present Value.....	19
6.6	Practice Problem 6 - Depreciation .....	19
7.0	Practice Exam Solutions .....	20



7.1	Solution 1 – Annual Value .....	20
7.2	Solution 2 – Present Value .....	20
7.3	Solution 3 – Rate of Return .....	21
7.4	Solution 4 – Simple Payback .....	22
7.5	Solution 5 – Present Value .....	23
7.6	Solution 6 - Depreciation .....	24

## 1.0 INTRODUCTION

Engineering Economics accounts for approximately 3 to 5 questions on the Electrical FE exam. As an engineer, you will be tasked with determining the course of action for a design. Often times this will entail choosing one alternative over several other design alternatives. You need to be able to present engineering economic analysis to your clients in order to justify why a certain alternative is more financially sound than the others. The following topics will present only the engineering economic concepts that you need for the FE exam and does not present a comprehensive look into the study of engineering economics. For the FE exam you are required to know the following concepts shown in the table below. Applicable equations for these topics can be found in the Engineering Economics section of the *NCEES FE Reference Handbook*.

Section 5.0 Engineering Economics (3 to 5 Problems)		
NCEES Outline Value	Engineering Pro Guides	
	Section 1.0	Introduction
5A	Section 2.0	Time Value of Money
5B	Section 3.0	Cost, Including Incremental, Average, Sunk and Estimating
5C	Section 4.0	Economic Analyses
5D	Section 5.0	Depreciation
	Section 6.0	Practice Exam Problems

## 2.0 TIME VALUE OF MONEY

### 2.1 FUTURE AND PRESENT VALUE

Before discussing interest rates, it is important that the engineer understands that money today is worth more than that same value of money in the future, due to factors such as inflation and interest. This is the time value of money concept. For example, if you were given the option to have \$1,000 today or to have \$1,000 ten years from now, most people will choose \$1,000 today, without understand why this option is worth more. The reason \$1,000 today is worth

# 5 – Properties of Electrical Materials

---

Chemical (e.g., corrosion, ions, diffusion), Electrical (e.g., conductivity, resistivity, permittivity, magnetic permeability), Mechanical (e.g., piezoelectric, strength), Thermal (e.g., conductivity, expansion)



# Section 5.0 – Properties of Electrical Materials

## Table of Contents

1.0	Introduction .....	3
2.0	Chemical (Corrosion, Ions, Diffusion) .....	3
2.1	Corrosion .....	4
2.1.1	Oxidation .....	5
2.1.2	Galvanic Series .....	6
2.1.3	Corrosion Protection.....	7
3.0	Electrical (Conductivity, Resistivity, Permittivity, Magnetic, Permeability).....	9
3.1	Conductivity .....	9
3.2	Resistivity .....	10
3.3	Permittivity .....	10
3.3.1	Capacitors .....	10
3.3.2	Transmission Lines .....	11
3.4	Magnetic.....	12
3.4.1	Retentivity.....	12
3.4.2	Coercive Force .....	12
3.4.3	Reluctance .....	12
3.5	Permeability.....	12
3.6	Inductors.....	13
4.0	Mechanical (Piezoelectric, Strength).....	13
4.1	Piezoelectric .....	13
4.2	Strength - Stress-Strain Diagrams.....	14
4.3	Strength - Young’s Modulus .....	14
4.4	Strength - Elastic Limit.....	15
4.5	Yield Strength .....	15
4.6	Proportional Limit.....	15
4.7	Shear Modulus .....	15
4.8	Poisson’s Ratio.....	15
4.9	Ultimate Tensile Strength .....	17
5.0	Thermal (Conductivity, Expansion) .....	18
5.1	Thermal Conductivity.....	18
5.2	Specific Heat Capacity .....	19



5.3	Thermal Expansion.....	20
6.0	Practice Exam Problems.....	22
6.1	Practice Exam Problem 1 – Corrosion .....	22
6.2	Practice Exam Problem 2 – Thermal Conductivity .....	22
6.3	Practice Exam Problem 3 – Electrical Conductivity.....	22
6.4	Practice Exam Problem 4 – Thermal Expansion .....	23
6.5	Practice Exam Problem 5 – Permeability .....	23
6.6	Practice Exam Problem 6 – Heat Capacity .....	23
7.0	Practice Exam Solutions .....	24
7.1	Practice Exam Solution 1 – Corrosion.....	24
7.2	Practice Exam Solution 2 – Thermal Conductivity.....	24
7.3	Practice Exam Solution 3 – Electrical Conductivity .....	25
7.4	Practice Exam Solution 4 – Thermal Expansion .....	26
7.5	Practice Exam Solution 5 - Permeability .....	26
7.6	Practice Exam Solution 6 – Heat Capacity .....	26



## 1.0 INTRODUCTION

Properties of Electrical Materials accounts for approximately 4 to 6 questions on the Electrical FE exam. The NCEES outline covers the following topics for electrical materials: chemical, electrical, mechanical and thermal. Remember that these topics are focused from an electrical engineering perspective. So under the chemical properties, the test will focus on corrosion because an electrical engineer must understand this topic in order to design sacrificial anode or cathodic protection systems. The electrical subtopic will cover the material properties that lead to the common electrical concepts like resistance, inductance and capacitance. The mechanical and thermal topics discuss how materials used in electrical engineering last and react in various conditions like under heat or cold or stress and strain.

Section 5.0 Properties of Electrical Materials (4 to 6 Problems)		
NCEES Outline Value	Engineering Pro Guides	
	Section 1.0	Introduction
5A	Section 2.0	Chemical (e.g., corrosion, ions, diffusion)
5B	Section 3.0	Electrical (e.g., conductivity, resistivity, permittivity, magnetic, permeability)
5C	Section 4.0	Mechanical (e.g., piezoelectric, strength)
5D	Section 5.0	Thermal (e.g., conductivity, expansion)
	Section 6.0	Practice Exam Problems

## 2.0 CHEMICAL (CORROSION, IONS, DIFFUSION)

The information you need to complete the problems on chemical properties of electrical materials can be found in the *NCEES FE Reference Handbook* – Chemistry Section.

There are a few chemical terms that you should be familiar with to make it easier and quicker to complete these few problems.

**Cathode** is where reduction occurs, which means it gains electrons. By definition, the movement of electrons is the opposite of current flow, so current flows away from the cathode. The cathode has the positive potential. Corrosion does not occur at the positive potential (i.e. voltage).

**Anode** is where oxidation (also known as rusting) occurs, which means it loses electrons. Current flows to the anode, which means the anode has the negative potential. The metal with the most negative potential (voltage) will corrode.

One way to remember these terms is through the term sacrificial anode. Sacrificial anodes are used to promote oxidation (rusting) on this material only. It sacrifices itself, in order to protect



# 6 – Engineering Sciences

---

Work, energy, power, heat, Charge, energy, current, voltage, power, Forces (e.g., between charges, on conductors), Work done in moving a charge in an electric field (relationship between voltage and work), Capacitance, Inductance





## Section 6.0 – Engineering Sciences

### Table of Contents

1.0	Introduction .....	2
2.0	Work, Energy, Power & Heat .....	3
2.1	Energy .....	3
2.1.1	Potential Energy .....	3
2.1.2	Kinetic Energy .....	3
2.1.3	Conservation of Energy .....	4
2.2	Work .....	4
2.2.1	Work-Energy Principle.....	4
2.3	Power .....	4
2.4	Heat .....	5
2.5	Mechanical-Electrical Power .....	5
2.5.1	Mechanical Horsepower (HP) .....	6
2.5.2	Fan or Pump Brake Horsepower .....	7
2.5.3	Motor Horsepower .....	8
2.5.4	Electrical Power.....	9
3.0	Charge, Energy, Current, Voltage & Power .....	10
3.1	Charge.....	10
3.2	Current.....	11
3.3	Voltage .....	12
3.4	Resistors.....	12
3.5	Power .....	13
3.6	Energy .....	14
4.0	Forces .....	14
4.1	Electrical Force.....	15
4.1.1	Point Charges.....	15
4.1.2	Electric Fields .....	16
4.2	Magnetic Force.....	18
4.3	Lorentz Force Law.....	18
4.4	Force on Current Carrying Wire .....	18
5.0	Work in a Moving Charge.....	19
6.0	Capacitance .....	20



7.0	Inductance.....	20
8.0	Practice Exam Problems.....	22
8.1	Practice Exam Problem 1 – Electrical Force .....	22
8.2	Practice Exam Problem 2 – Electric Field .....	22
8.3	Practice Exam Problem 3 – Capacitance .....	23
8.4	Practice Exam Problem 4 – Inductance .....	23
8.5	Practice Exam Problem 5 – Work, Energy, Power & Heat .....	24
8.6	Practice Exam Problem 6 – Work, Energy, Power & Heat .....	24
8.7	Practice Exam Problem 7 – Work Due to Electric Field.....	25
8.8	Practice Exam Problem 8 – Capacitance .....	25
8.9	Practice Exam Problem 9 – Inductance .....	26
9.0	Practice Exam Solutions .....	27
9.1	Practice Exam Solution 1 – Electrical Force.....	27
9.2	Practice Exam Solution 2 – Electric Field .....	27
9.3	Practice Exam Solution 3 – Capacitance .....	28
9.4	Practice Exam Solution 4 – Inductance.....	28
9.5	Practice Exam Solution 5 - Work, Energy, Power & Heat .....	29
9.6	Practice Exam Solution 6 - Work, Energy, Power & Heat .....	30
9.7	Practice Exam Solution 7 – Work Due to Electric Field.....	30
9.8	Practice Exam Solution 8 – Capacitance .....	31
9.9	Practice Exam Solution 9 - Inductance.....	31

## 1.0 INTRODUCTION

The Engineering Sciences topic covers 6 to 9 questions on work, energy, power, heat, charge, forces, capacitance and inductance. These are all the topics that lead up to the Electromagnetics topic in Section 12. It also elaborates the previous section Properties of Electrical Materials from the materials perspective to the actual device behavior. For example, Properties of Electrical materials focused on the materials used to make an inductor and the properties of those materials. This topic shows how material characteristics are used to calculate the voltage difference and the energy across an inductor.

<b>Section 6.0 Engineering Sciences (6 to 9 Problems)</b>	
<b>NCEES Outline Value</b>	<b>Engineering Pro Guides</b>
Section 1.0	Introduction



6A	Section 2.0	Work, Energy, Power & Heat
6B	Section 3.0	Charge, Energy, Current, Voltage & Power
6C	Section 4.0	Forces (e.g. between charges on conductors)
6D	Section 5.0	Work (moving charge in electric field, voltage relationship with work)
6E	Section 6.0	Capacitance
6F	Section 7.0	Inductance
	Section 8.0	Practice Exam Problems

## 2.0 WORK, ENERGY, POWER & HEAT

These topics are very broad, but when applied to electrical engineering, they become focused on the work and energy that results from the electrical and magnetic forces as well as the power and heat produced by motors and generators. The latter is where these topics begin to overlap with mechanical engineering.

The following descriptions focus on the broader definition of work, energy and power. Work, energy, and power are discussed again later in this section, but in how it relates to circuits and charge.

### 2.1 ENERGY

Energy is the capacity to do work. It comes in many forms: thermal, electrical, mechanical, chemical, electromagnetic, etc. Energy is given in units of joules, watt-hours (electrical energy), ft-lb, or Btu (heat). The two major types of energy used in electrical engineering are potential and kinetic energy.

#### 2.1.1 Potential Energy

Potential energy is the energy that is stored. In the physical world, that means the energy stored in an object due to its height, like when a ball ready to drop, or the energy stored in a compressed spring. In electrical engineering there is potential energy in a battery.

See the next topic, 3.0 Charge, Energy, Current, Voltage & Power, for energy calculations related to batteries, capacitors, and inductors.

#### 2.1.2 Kinetic Energy

Kinetic Energy (KE) is the energy of a particle due to motion. Imagine a moving car. Since you know it will take an enormous amount of energy to stop it, it must mean there is energy in its movement. The heavier it is or the faster the car is moving, the more energy it has.

$$KE = \frac{1}{2}mv^2 \text{ (linear movement)}$$

*SI Units: KE = kinetic energy (J); m = mass (kg); v = velocity (m/s)*

In electrical engineering we are interested in the kinetic energy from moving electrical charges. The equation above can be used to calculate the energy from a moving charge with mass,  $m$ .

### 2.1.3 Conservation of Energy

The law of conservation of energy states that energy in a closed system with no external forces remains constant. Thus the sum of the total energy at time  $t = 1$  must equal the total energy at time  $t = 2$ . This is an important concept to understand. Essentially the energy must go somewhere. Potential energy can be converted to kinetic energy, i.e. a ball drops: the potential energy turns into kinetic energy of the falling ball.

$$\text{Conservation of Energy} \rightarrow KE_1 + PE_1 = KE_2 + PE_2$$

## 2.2 WORK

You also need to understand the difference between work and energy. Work is the amount of energy used to move an object and is defined as the product of a force vector and the caused displacement. The work of a force acting upon a displacement is shown as the equation below.

$$W = F * \Delta d$$

$$F = N \text{ or } lb; \Delta d = m, ft. \text{ or } in.$$

$$W = N - m \text{ or Joule}; W = lb - ft \text{ or } lb - in$$

### 2.2.1 Work-Energy Principle

Work has the same units as energy, so it can also be added to the conservation of energy equations to produce the work-energy principle. The principle states that the work done on an object is transferred to kinetic energy and vice versa.

$$\text{Work Energy Principle} \rightarrow W_1 + KE_1 + PE_1 = W_2 + KE_2 + PE_2$$

The basic concept is that energy is conserved or transferred to work. You can use these conservation equations to solve for unknowns. You should use Work-Energy equations for when the length of time is not a factor.

## 2.3 POWER

Power is a rate of energy or work. In electrical engineering application, a generator produces electrical power or a motor requires electrical power.

# 7 – Circuit Analysis

---

KCL, KVL, Series/parallel equivalent circuits, Thevenin and Norton theorems, Node and loop analysis, Waveform analysis (e.g., RMS, average, frequency, phase, wavelength), Phasors, Impedance



# Section 7.0 – Circuit Analysis

## Table of Contents

1.0	Introduction .....	3
2.0	Direct Current.....	4
2.1	Ohm's Law.....	4
2.2	Electrical Power.....	4
2.3	Kirchhoff's Laws .....	5
2.3.1	Kirchhoff's Voltage Law (KVL).....	5
2.3.2	Kirchhoff's Current Law (KCL).....	6
2.4	Circuit Arrangements.....	6
2.4.1	Series Circuits .....	7
2.4.2	Parallel Circuits .....	8
2.4.3	Open Circuit .....	9
2.4.4	Short Circuit.....	9
2.4.5	Multiple Sources (Superposition Theorem).....	10
2.5	Inductors & Capacitors .....	13
2.5.1	Inductors.....	13
2.5.2	Inductor Characteristics.....	15
2.5.3	Inductors in Parallel.....	16
2.5.4	Inductors in Series.....	16
2.5.5	Capacitors .....	16
2.5.6	Capacitor Characteristics .....	18
2.5.7	Capacitors in Parallel .....	19
2.5.8	Capacitor in Series .....	19
3.0	Thevenin & Norton Theorems .....	19
3.1	Thevenin Equivalent.....	19
3.2	Norton Equivalent.....	22
4.0	Node and Loop Analysis .....	24
4.1	Node Analysis.....	24
4.2	Loop/Mesh Analysis .....	28
5.0	Waveform Analysis .....	32
5.1	Frequency.....	33
5.2	RMS and MAX.....	33



6.0	Phasors .....	36
6.1	Rectangular Form.....	37
6.2	Polar Form.....	37
6.3	Converting Polar and Rectangular Forms - Calculator.....	38
7.0	Impedance .....	40
7.1	Resistance (Resistors) .....	40
7.2	Inductance or Inductive Reactance (Inductors).....	41
7.3	Capacitance or Capacitive Reactance (Capacitors).....	41
7.4	Impedance.....	41
8.0	Practice Exam Problems.....	43
8.1	Practice Exam Problem 1 - Thevenin .....	43
8.2	Practice Exam Problem 2 – Norton .....	44
8.3	Practice Exam Problem 3 – KVL .....	44
8.4	Practice Exam Problem 4 – KCL .....	45
8.5	Practice Exam Problem 5 – Series/Parallel Circuits.....	45
8.6	Practice Exam Problem 6 – Series/Parallel Circuits.....	46
8.7	Practice Exam Problem 7 – Impedance .....	46
8.8	Practice Exam Problem 8 - Impedance .....	47
8.9	Practice Exam Problem 9 – Waveform Analysis .....	47
8.10	Practice Exam Problem 10 – Phasors.....	48
8.11	Practice Exam Problem 11 - Phasors.....	48
8.12	Practice Exam Problem 12 – Impedance .....	49
8.13	Practice Exam Problem 13 – Impedance .....	49
8.14	Practice Exam Problem 14 - Waveform Analysis .....	50
8.15	Practice Exam Problem 15 - Waveform Analysis .....	50
9.0	Practice Exam Solutions .....	51
9.1	Practice Exam Solution 1 – Thevenin.....	51
9.2	Practice Exam Solution 2 - Norton .....	53
9.3	Practice Exam Solution 3 - KVL .....	55
9.4	Practice Exam Solution 4 - KCL .....	56
9.5	Practice Exam Solution 5 - Series/Parallel Circuits.....	57
9.6	Practice Exam Solution 6 - Series/Parallel Circuits.....	57
9.7	Practice Exam Solution 7 – Impedance.....	58
9.8	Practice Exam Solution 8 – Impedance.....	59



9.9	Practice Exam Solution 9 – Waveform Analysis.....	59
9.10	Practice Exam Solution 10 - Phasors .....	60
9.11	Practice Exam Solution 11 - Phasors .....	61
9.12	Practice Exam Solution 12 - Impedance .....	62
9.13	Practice Exam Solution 13 – Impedance.....	62
9.14	Practice Exam Solution 14 – Waveform Analysis.....	63
9.15	Practice Exam Solution 15 - Waveform Analysis.....	63

## 1.0 INTRODUCTION

Circuit Analysis accounts for approximately 10 to 15 questions on the Electrical FE exam. These questions can cover the following NCEES outline topics: KCL, KVL, series & parallel equivalent circuits, Thevenin & Norton theorems and node & loop analysis. These topics are all techniques that you can use to simplify complex DC (direct current) circuits. Each of these techniques are discussed in detail with example problems in this section. The next three topics from the NCEES outline are waveform analysis, phasors and impedance. These topics are most often covered under AC (alternating current) circuits. The NCEES outline also specifically states that this topic covers DC & AC circuits in steady state. Thus, the transient response for circuits is discussed in a different section, Section 8.0 Linear Systems.

The Electrical and Computer Engineering section of the *NCEES FE Reference Handbook* has all of the basic equations you need to solve any circuit analysis problem, like KCL, KVL series, parallel, etc. However, it is recommended that you read through the following section, complete the practice problems and commit the common equations to memory. This will save you a lot of time on the many easy questions that should come out of this topic, which can then be used for the more complex questions.

Section 7.0 Circuit Analysis (10 to 15 Problems)		
NCEES Outline Value	Engineering Pro Guides' Topic	
	Topic 1.0	Introduction
7A	Topic 2.0	KCL and KVL
7B	Topic 2.0	Series/Parallel Equivalent Circuits
7C	Topic 3.0	Thevenin and Norton Theorems
7D	Topic 4.0	Node and Loop Analysis
7E	Topic 5.0	Waveform Analysis
7F	Topic 6.0	Phasors
7G	Topic 7.0	Impedance
	Topic 8.0	Practice Exam Problems



## 2.0 DIRECT CURRENT

As discussed in the previous section, 6.0 Engineering Sciences, direct current (DC) is the supply of current in one direction. Current is positive when it flows from the positive voltage terminal to the negative.

There are three main elements to a basic circuit: (1) current, (2) voltage and (3) resistance. The flow of electrons in a circuit is called current ( $I$ ) and current is given in units of amperes. The energy that drives the flow of electrons is called the voltage ( $V$ ) and is given in units of volts. The voltage is measured between two points because it is the difference in energy (also known as the potential) that drives the current from one point to the next. The third term is resistance, which is measured in units of ohms ( $\Omega$ ). Resistance ( $R$ ) is the opposition to the flow of current. One ohm is described as the level of resistance that will allow 1 ampere to flow when 1 volt is applied to a circuit.

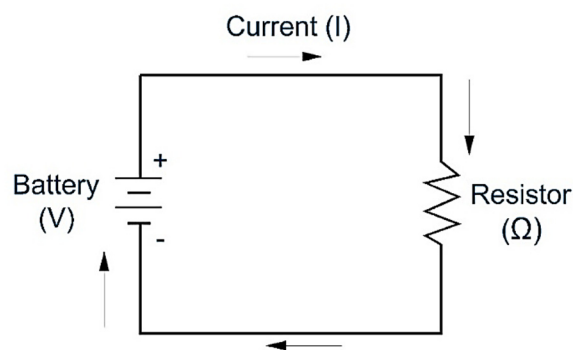

Figure 1: A basic DC circuit, current flows from positive to negative.

Current is constantly run in a circuit to maintain power to loads, which are identified as resistors.

### 2.1 OHM'S LAW

Recall that Ohm's law describes the relationship between voltage, resistance and current.

$$\text{Ohm's Law} \rightarrow V = IR$$

$$V = \text{voltage (volts)}; I = \text{current (amperes)}; R = \text{ohms } (\Omega)$$

This is the basic equation used in circuit analysis.

### 2.2 ELECTRICAL POWER

Also review the real power equations, which are given in terms of watts.

$$\text{Real Power (watts)} \rightarrow P = IV = I^2R = \frac{V^2}{R}$$

# 8 – Linear Systems

---

Frequency/transient response, Resonance, Laplace transforms, Transfer functions, 2-port theory



# Section 8.0 – Linear Systems

## Table of Contents

1.0	Introduction .....	2
2.0	Frequency/Transient Response .....	3
2.1	RL Transient Response .....	3
2.2	RL Frequency Response .....	5
2.2.1	High Pass/Low Pass Filters .....	5
2.3	RC Transient Response .....	6
2.4	RC Frequency Response .....	8
2.4.1	High Pass/Low Pass Filters .....	9
3.0	Resonance .....	10
3.1	Series RLC Resonance .....	11
3.1.1	Series RLC Resonant Frequency .....	11
3.1.2	Series RLC Bandwidth .....	12
3.2	Parallel RLC Resonance .....	13
3.2.1	Parallel RLC Resonant Frequency .....	13
3.2.2	Parallel RLC Bandwidth .....	14
3.2.3	Parallel RLC Bandwidth – Current Source .....	15
4.0	Laplace Transforms .....	16
4.1	Laplace & Z Transform Pairs .....	21
4.2	Laplace Properties .....	22
4.2.1	Linearity .....	22
4.2.2	First, Second & N <sup>th</sup> Derivative .....	23
4.2.3	Integral .....	24
4.2.4	Time Multiplication/Division .....	24
4.2.5	Time Delay/Advancement .....	25
4.2.6	Complex Shift .....	25
4.2.7	Scale .....	26
4.2.8	Convolution .....	26
5.0	Transfer Functions .....	26
5.1	Poles & Zeroes .....	26
6.0	Two-Port Theory .....	27
6.1	Impedance Parameters .....	31



6.2	Relationship Between Other Methods .....	33
7.0	Practice Exam Problems.....	34
7.1	Practice Exam Problem 1 – 2 Port Theory .....	34
7.2	Practice Exam Problem 2 – 2 Port Theory .....	34
7.3	Practice Exam Problem 3 – Laplace Transform .....	35
7.4	Practice Exam Problem 4 – Laplace Transform .....	35
7.5	Practice Exam Problem 5 – Transfer Function.....	36
7.6	Practice Exam Problem 6 – Transfer Function.....	36
7.7	Practice Exam Problem 7 – Frequency/Transient Response .....	37
7.8	Practice Exam Problem 8 – Frequency/Transient Response .....	37
8.0	Practice Exam Solutions .....	38
8.1	Practice Exam Solution 1 – 2 Port Theory.....	38
8.2	Practice Exam Solution 2 – 2 Port Theory.....	38
8.3	Practice Exam Solution 3 – Laplace Transform .....	39
8.4	Practice Exam Solution 4 – Laplace Transform .....	39
8.5	Practice Exam Solution 5 – Transfer Function .....	40
8.6	Practice Exam Solution 6 – Transfer Function .....	42
8.7	Practice Exam Solution 7 – Frequency/Transient Response .....	43
8.8	Practice Exam Solution 8 – Frequency/Transient Response .....	44

## 1.0 INTRODUCTION

Linear Systems accounts for approximately 5 to 8 questions on the Electrical FE exam. The Linear Systems topic on the NCEES exam covers frequency response, transient response, resonance, Laplace transforms, transfer functions & 2-port theory. Linear Systems also overlaps with NCEES FE Electrical topic called Control Systems. Control Systems moves closer to application in electrical engineering, while this Linear Systems topic focuses more on the mathematics side of control systems.

The *NCEES FE Reference Handbook* Electrical Engineering section has some basic equations for the topics below, but it does not explain the skills and concepts necessary to use these equations. The Laplace Transform tables are located in the Mathematics section. The resonance equations are located in the Electrical & Computer Engineering section, along with the Two-Port Theory equations. If you like to use the search function you can search the keywords, Laplace, Frequency, Resonance and Two-Port.

## Section 8.0 Linear Systems (5 to 8 Problems)

NCEES Outline Value	Engineering Pro Guides	
	Section 1.0	Introduction
8A	Section 2.0	Frequency/Transient Response
8B	Section 3.0	Resonance
8C	Section 4.0	Laplace Transforms
8D	Section 5.0	Transfer Functions
8E	Section 6.0	2-Port Theory
	Section 7.0	Practice Exam Problems

## 2.0 FREQUENCY/TRANSIENT RESPONSE

There are two ways to look at the response of your system, (1) Transient and (2) Frequency. The frequency response looks at the response of your system in the frequency domain and the transient response focuses on the time domain. Transient response occurs when there is a change in a system and it is not yet at steady state. There are two main transient response concepts that you should understand for the exam, since these concepts are shown in the *NCEES FE Reference Handbook* under the Electrical & Computer Engineering section. These concepts revolve around the RL and RC circuits, shown in the next two parts.

### 2.1 RL TRANSIENT RESPONSE

The resistor-inductor (RL) circuit consists of inductors (L) and resistors (R). The circuit will respond to a sinusoidal voltage input, based on its inductance and resistance values. Resistors will only affect the circuit by its ohm value. Inductors will respond to the rate of change in current. As current is quickly decreased, the inductor will produce more voltage, in its release of stored energy from its magnetic field to try to keep current constant. If current is slowly decreased, the inductor will produce relatively less voltage, by releasing less stored energy from its magnetic field, to try and keep the current constant. This is seen by the equation  $V_L(t) = L * \left(\frac{di}{dt}\right)$ .

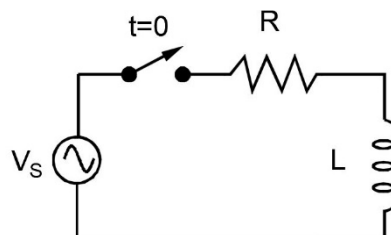

Figure 1: This circuit shows a switch that is activated at time  $t = 0$  seconds. When the switch is activated, the sinusoidal (AC) voltage source will be connected to the resistor and inductor in series.

The charging and discharging portions shown in the inductor current/voltage versus time graph represent the transient response regions; see the figure below. The governing equation for the current through this circuit, after the switch is latched at time  $t = 0$ , is shown by the equation below.

$$i(t) = i(0)e^{-Rt/L} + \frac{V_s}{R} * \left(1 - e^{-\frac{Rt}{L}}\right)$$

Most times, the initial value will be equal to zero, so the above equation can be simplified to the following equation.

$$\text{Assume } i(0) = 0$$

$$i(t) = \frac{V_s}{R} * \left(1 - e^{-\frac{Rt}{L}}\right)$$

The voltage across the resistor will now be a function of the current multiplied by the resistance value.

$$V_{resistor} = I * R \rightarrow V_{Resistor}(t) = \left[\frac{V_s}{R} * \left(1 - e^{-\frac{Rt}{L}}\right)\right] * R = V_s * \left(1 - e^{-\frac{Rt}{L}}\right)$$

The voltage across the inductor will be the voltage source minus the voltage across the resistor.

$$V_{inductor} = V_s - V_{resistor}$$

$$V_{inductor} = V_s - V_s * \left(1 - e^{-\frac{Rt}{L}}\right) = V_s e^{-\frac{Rt}{L}}$$

On the actual FE exam, you may have to simplify complex circuits and put it into the same resistor-inductor format as the one shown in the RL circuit figure above. This will require an understanding of the Thevenin techniques, but will allow you to use the voltage equation above. Another question that could be asked is to find the time constant of the circuit. The time constant is found through the below equation.

$$\text{Time Constant} = \tau = \frac{L}{R}$$

The time constant represents the amount of time it takes to store energy in the inductor. At time  $t = \tau$ , the exponent becomes  $e^{-1} = 0.368$ . This means if a constant DC voltage source is applied, then at 1 time constant, the voltage across the inductor will be 36.8% of the source voltage and the current through the circuit will be 63% of the current through the circuit. At time  $t = 5 * \tau$ , the current will be 99.3% of the max current. The current will very slowly increase from there, so the inductor will essentially be at steady state.

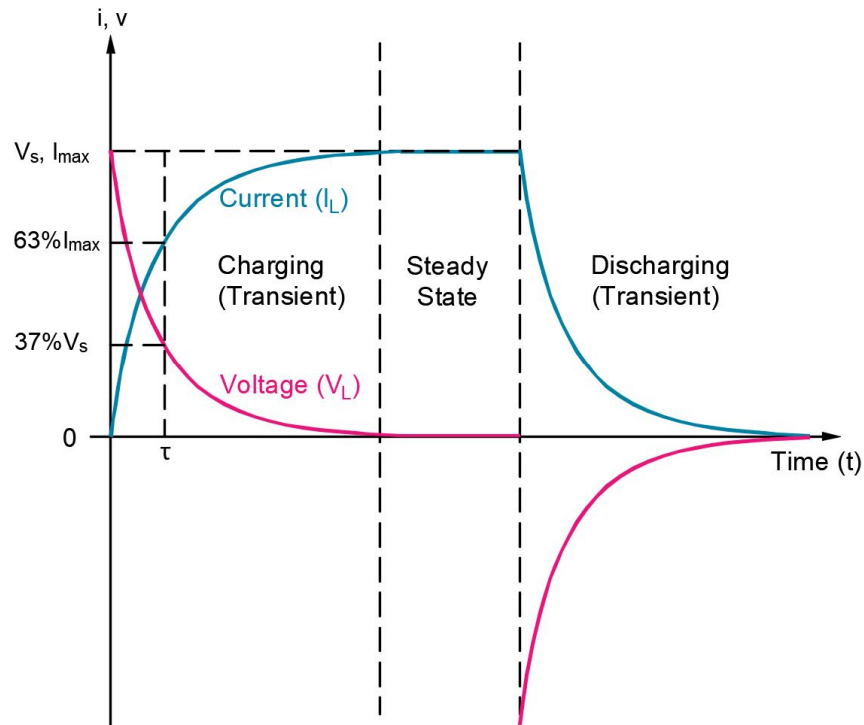

Figure 2: The graph shows current and voltage across an inductor as it is in its transient and steady states. The current will be at 63% when time is equal to the time constant,  $\tau = L/R$ .

The other way to look at inductors is the previously mentioned equation from the basic circuits section, where it states that the voltage across an inductor is equal to the inductance multiplied by the change in current.

$$V_L(t) = L * \left( \frac{dI}{dt} \right)$$

## 2.2 RL FREQUENCY RESPONSE

The RL circuit can also be analyzed in the frequency domain. In the frequency domain the resistor and inductor will respond differently to various frequencies. The impedance of the resistor and inductor equations are shown below. These equations show that as the frequency increases, the impedance of the inductor will increase and as the frequency decreases, the impedance of the inductor will decrease. This is why at DC voltage (frequency = 0), the inductor has 0 impedance and acts like a short circuit.

$$Z_R = R + 0j; Z_L = 0 + j(2\pi f * L); f = \text{Frequency (Hz)}$$

$$Z_R = R + 0j; Z_L = 0 + j(\omega L); \omega = \text{Frequency (radians/s)}$$

### 2.2.1 High Pass/Low Pass Filters

RL circuits can also be used to create high pass and low pass filters using frequency response. The important relationship to know is the cutoff frequency,  $f_c$ . This is the frequency that the circuit is intended to filter to. The cutoff frequency for an RL circuit is shown below.

# 9 – Signal Processing

---

Convolution (continuous and discrete), Difference equations, Z-transforms, Sampling (e.g., aliasing, Nyquist theorem), Analog filters, Digital filters





# Section 9.0 – Signal Processing

## Table of Contents

1.0	Introduction .....	2
2.0	Convolution .....	3
2.1	Continuous-Time Convolution .....	4
2.1.1	Convolution by Graphing .....	5
2.2	Discrete-Time Convolution .....	8
2.3	Convolution Properties .....	11
2.3.1	Identity Property (Delta Function).....	11
2.3.2	Scalar Property.....	11
2.3.3	Commutative Property.....	12
2.3.4	Associative Property.....	12
2.3.5	Distributive Property .....	12
3.0	Z-Transforms.....	13
3.1	Z-Transform Pairs.....	14
3.1.1	Z-Transform - Delta Function .....	14
3.1.2	Z-Transform - Step Function .....	15
3.1.3	Z-Transform - Exponential Function.....	15
3.1.4	Z-Transform - Ramp Function .....	16
3.1.5	Z-Transform - Parabola Function .....	16
3.2	Z-Transform Properties .....	17
3.2.1	Linearity.....	17
3.2.2	Time Expansion & Reduction .....	17
3.2.3	Time Shift .....	17
3.2.4	Convolution .....	18
3.2.5	Time Difference .....	18
3.2.6	Time Scaling.....	19
3.2.5	Z-Domain Differentiation .....	19
4.0	Difference Equations.....	19
4.1	First Order Difference Equations .....	19
4.2	Second Order Difference Equations.....	20
5.0	Analog Filters .....	21
5.1	First Order Low Pass Filter .....	21



5.2	First Order High Pass Filter .....	22
5.3	Band-Pass Filter .....	24
5.4	Band-Reject Filter .....	26
6.0	Sampling .....	28
6.1	Nyquist's Sampling Theorem.....	28
6.2	Aliasing .....	28
7.0	Digital Filters .....	29
8.0	Practice Exam Problems.....	30
8.1	Practice Exam Problem 1 – Z-Transform .....	30
8.2	Practice Exam Problem 2 – Convolution .....	30
8.3	Practice Exam Problem 3 – Z-Transform .....	31
8.4	Practice Exam Problem 4 - Convolution .....	31
8.5	Practice Exam Problem 5 - Filters .....	32
8.6	Practice Exam Problem 6 - Filters .....	32
9.0	Practice Exam Solutions .....	33
9.1	Practice Exam Solution 1 – Z-Transform.....	33
9.2	Practice Exam Solution 2 - Convolution .....	33
9.3	Practice Exam Solution 3 – Z-Transform.....	36
9.4	Practice Exam Solution 4 – Convolution .....	37
9.5	Practice Exam Solution 5 – Filters.....	38
9.6	Practice Exam Solution 6 – Filters.....	39

## 1.0 INTRODUCTION

Signal processing in electrical engineering is used to extract information from electrical circuits. Current and voltage will vary with time, based on the characteristics of the circuit. Signals can be sent along electrical circuits from one location to another. At the final location, these signals must then be processed. This section will go over the basics of signal processing as it relates to the Electrical FE exam. Signal Processing accounts for approximately 5 to 8 questions on the Electrical FE exam. These questions can cover convolution, difference equations, Z-transforms, sampling, analog filters and digital filters.

The *NCEES FE Reference Handbook* contains very basic information on difference equations and convolution. This seems to indicate that any problems on these topics will be more conceptual as opposed to computational. On the other hand, the handbook contains tables for the Z-transforms for various functions and tables for various analog filters. So questions on these topics will be more computational. In addition, digital filters use Z-transforms heavily, so problems on digital filters will most likely be computational. Lastly, the handbook has information on various



sampling methods, so these questions could also be computational. Although sampling is called for in the outline under Signal Processing, sampling is also typically a part of Communications in electrical engineering courses. Thus, there will be some overlap between this section and Section 14.0 Communications.

Section 9.0 Signal Processing (5 to 8 Problems)		
NCEES Outline Value	Engineering Pro Guides Topics	
	Topic 1.0	Introduction
9A	Topic 2.0	Convolution (continuous and discrete)
9C	Topic 3.0	Z-Transforms
9B	Topic 4.0	Difference Equations
9E	Topic 5.0	Analog Filters
9D	Topic 6.0	Sampling (e.g., aliasing, Nyquist theorem)
9F	Topic 7.0	Digital Filters
	Topic 8.0	Practice Exam Problems

## 2.0 CONVOLUTION

The first concept that you must know for the Electrical FE exam Signal Processing topic is convolution. Convolution involves combining two signals to make a third signal. The NCEES outline specifically calls out two methods of convolution, (1) continuous time and (2) discrete time.

**Discrete Time:** A discrete time signal is shown by pulses at various points of time.

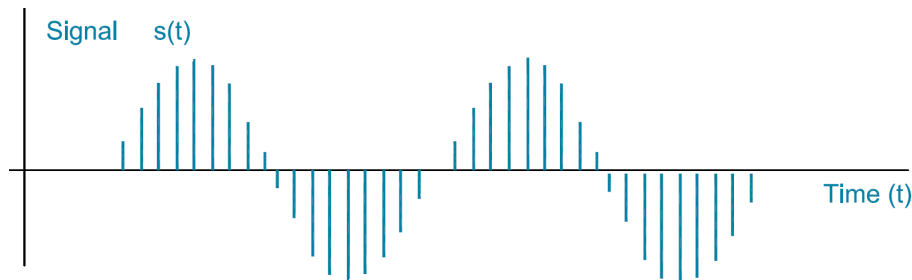

Figure 1: A discontinuous aka discrete time signal is shown by this figure. The signal has breaks, meaning there isn't a y-value for every x-value (any point in time).

**Continuous Time:** A continuous time signal is shown by a continuous pulse that can vary its amplitude over time.

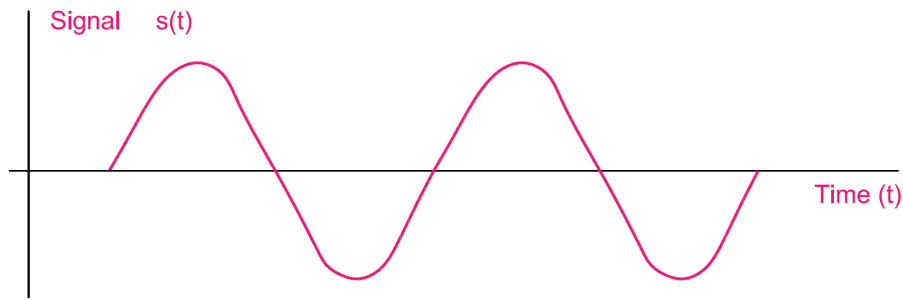

Figure 2: A continuous time signal is shown by this figure. The signal has no breaks, meaning there is a  $y$ -value for every  $x$ -value (any point in time).

Convolution is a mathematical operation involving the input signal, impulse response, and output signal.

## 2.1 CONTINUOUS-TIME CONVOLUTION

The convolution of continuous signals in the time domain is represented by the equation below. Do not confuse the "\*" symbol for a multiplication symbol. Instead, the symbol is another mathematical operation that means the two functions,  $x(t)$  and  $h(t)$ , are integrated with the following format. Pay attention to the exam questions. If it asks you to find the convolution of signals, then you should know to use this equation.

$$y(t) = x(t) * h(t) = \int_{-\infty}^{+\infty} x(\tau)h(t - \tau)d\tau$$

Convolution of the continuous time function can also be depicted by the block diagram below.

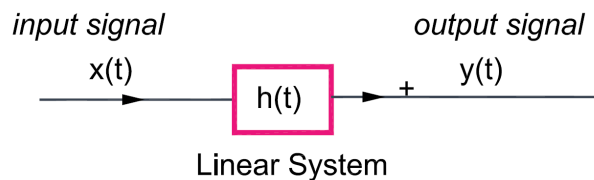

Figure 3: Block diagram of a continuous-time convolution with input  $x(t)$ , impulse response  $h(t)$ , and output  $y(t)$ .

To better understand what is going on, let us first define  $h(t)$ . In the equation above,  $h(t)$  is the impulse response of a linear, time invariant system. If you were to send a unit impulse signal through a system, the output would be the impulse response. (Refer to Section 8.0 Linear Systems for the definition of a linear system. A time invariant system means that it does not matter when you send a signal through a system, the output will be the same. A unit impulse is a sharp spike in a signal, infinitely tall with the area under its curve equal to one.)

# 10 - Electronics

---

Solid-state fundamentals (e.g., tunneling, diffusion/drift current, energy bands, doping bands, p-n theory), Discrete devices (diodes, transistors, BJT, CMOS) and models and their performance, Bias circuits, Amplifiers (e.g., single-stage/common emitter, differential), Operational amplifiers (ideal, non-ideal), Instrumentation (e.g., measurements, data acquisition, transducers), Power electronics



# Section 10.0 – Electronics

## Table of Contents

1.0	Introduction .....	3
2.0	Solid-State Fundamentals .....	3
2.1	Silicon & Germanium n-type & p-type .....	4
2.2	Conductivity .....	4
2.3	Diffusion & Drift Current.....	5
3.0	Discrete Devices .....	5
3.1	Diodes .....	5
3.1.1	Bias .....	6
3.1.2	Thermal Voltage .....	7
3.1.3	Zener Diode.....	7
3.2	Thyristor.....	8
3.3	Insulated Gate Bipolar Transistors .....	9
3.4	Bipolar Junction Transistor (BJT) .....	9
3.4.1	Common Base Configuration .....	11
3.4.2	Common Emitter Configuration .....	12
3.4.3	Common Collector Configuration .....	13
4.0	Bias Circuits .....	14
4.1	Junction Field Effect Transistor (JFET) .....	14
4.1.1	N-Channel JFET.....	14
4.1.2	P-Channel JFET.....	16
4.2	Metal Oxide Semiconductor Field Effect Transistor (MOSFET).....	17
5.0	Operational Amplifiers.....	18
5.1	Inverted Operational Amplifier .....	19
5.2	Non-Inverted Operational Amplifier .....	20
5.3	Summing Operational Amplifier.....	21
5.4	Common Mode Rejection Ratio.....	21
5.5	Differential Amplifier .....	22
7.0	Instrumentation .....	23
7.1	Temperature Measurements & Transducers.....	23
7.2	Strain Measurements & Transducers .....	24
7.3	Pressure Transducers .....	27



7.4	Propagation of Error .....	28
8.0	Power Electronics .....	29
8.1	Rectifiers.....	29
8.1.1	Half-Wave Rectifiers.....	29
8.1.2	Full-Wave Rectifiers .....	30
8.1.3	DC Bus Ripple.....	32
8.1.4	Full-Wave Rectifier with Capacitor .....	32
8.1.5	Single Phase Half Wave Rectifier .....	33
8.1.6	Single Phase Full Wave Rectifier .....	34
8.1.7	Three Phase Half Wave Rectifier .....	36
8.1.8	Three Phase Full Wave Rectifier.....	38
8.2	Inverters.....	40
9.0	Practice Exam Problems.....	41
9.1	Practice Exam Problem 1 – Power Electronics .....	41
9.2	Practice Exam Problem 2 - Power Electronics .....	41
9.3	Practice Exam Problem 3 – Operational Amplifiers.....	42
9.4	Practice Exam Problem 4 – Operational Amplifiers.....	42
9.5	Practice Exam Problem 5 – Operational Amplifier .....	43
9.6	Practice Exam Problem 6 – Differential Amplifier .....	43
9.7	Practice Exam Problem 7 – Collector Voltage.....	44
9.8	Practice Exam Problem 8 – Collector Current.....	44
9.9	Practice Exam Problem 9 - Instrumentation .....	45
10.0	Practice Exam Solutions .....	46
10.1	Practice Exam Solution 1 – Power Electronics.....	46
10.2	Practice Exam Solution 2 – Power Electronics.....	46
10.3	Practice Exam Solution 3 – Operational Amplifiers .....	47
10.4	Practice Exam Solution 4 – Operational Amplifiers .....	48
10.5	Practice Exam Solution 5 – Operational Amplifier .....	48
10.6	Practice Exam Solution 6 – Differential Amplifier .....	49
10.7	Practice Exam Solution 7 – Collector Voltage .....	50
10.8	Practice Exam Solution 8 – Collector Current .....	51
10.9	Practice Exam Solution 9 –Instrumentation.....	52



## 1.0 INTRODUCTION

Electronics accounts for approximately 7 to 11 questions on the Electrical FE exam. These questions can cover solid state fundamentals, which includes tunneling, diffusion current, drift current, energy bands, doping bands and p-n theory. Also included in this topic are discrete devices that make up electronics circuits. These devices include diodes, transistors, bipolar junction transistors (BJT) and complementary metal oxide semiconductors (CMOS, MOSFET). Other devices used in electronics have their own subtopics like amplifiers, operational amplifiers, bias circuits and instrumentation. The last subtopic is power electronics which would include rectifier circuits.

The *NCEES FE Reference Handbook* Electrical and Computer Engineering section has an operational amplifiers section with only inverted, non-inverted and common mode op-amps. The solid state electronics devices section has brief information on the solid state fundamentals, but a lot more on differential amplifiers, diodes, thyristors, silicon controlled rectifiers, BJTs, JFETs and MOSFETs. It appears that the questions on this section will focus primarily on these devices used in electronics as opposed to the solid state theory. Finally, there are only a few lines on the power side of electronics and this seems to overlap with the next Section 11.0 Power. So the power electronics will be briefly covered in this section and for more information, you should read the following Section 11.0 Power.

Section 10.0 Electronics (7 to 11 Problems)		
NCEES Outline Value	Engineering Pro Guides	
	Section 1.0	Introduction
10A	Section 2.0	Solid-State Fundamentals
10B	Section 3.0	Discrete Devices
10C	Section 4.0	Bias Circuits
10D	Section 5.0	Amplifiers
10E	Section 6.0	Operational Amplifiers
10F	Section 7.0	Instrumentation
10G	Section 8.0	Power Electronics
	Section 9.0	Practice Exam Problems

## 2.0 SOLID-STATE FUNDAMENTALS

Solid state electronics do not have any moving parts to conduct control in electronics. The purpose of learning solid-state fundamentals is to understand the underlying concepts behind the individual parts that make up solid state controls, which are heavily used in electronics.



## 2.1 SILICON & GERMANIUM N-TYPE & P-TYPE

Silicon and Germanium are used as materials for semi-conductors. These two elements have the same amount of electrons, which is 4. Germanium has one more electron shell than silicon. These two concepts allow the materials to be doped aka adding atoms of different elements into the crystal structure. This is done by gassing the material.

If the material is doped with a gas that has 5 valence electrons, then the material becomes an n-type (negative) semi-conductor, since there are a surplus of electrons (insufficient amount of holes or empty electron spots). Doping materials with 5 valence electrons include antimony, arsenic and phosphorous.

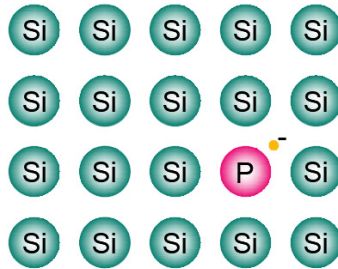

Figure 1: N-type silicon semi-conductor doped with phosphorous to add an extra electron per phosphorous atom.

If the material is doped with a gas that has 3 valence electrons, then the material becomes a p-type (positive) semi-conductor, because there are a surplus of holes (empty electron spots). Doping materials with 3 valence electrons include boron, gallium and aluminum.

## 2.2 CONDUCTIVITY

One possible equation that the FE exam could test you with is the ionic conductivity equation. This equation is used when an electric field is applied, which causes electrons to move.

$$\sigma = q(n\mu_n + p\mu_p)$$

$$\sigma = \text{conductivity} \left( \frac{A}{V} \right); q = \text{charge on electron} (1.6 \times 10^{-19} C)$$

$$\mu_n = \text{electron mobility} \left( \frac{m}{s} * \frac{m}{V} \right); \mu_p = \text{hole mobility} \left( \frac{m}{s} * \frac{m}{V} \right)$$

$$n = \text{electron concentration} \left( \frac{\#}{m^2} \right); p = \text{hole concentration} \left( \frac{\#}{m^2} \right)$$

Positively excess ions are called cations. Negatively excess ions are called anions. Some people use the mnemonic, Cats have paws to remember that cations are “paws”-itive. This makes anions negative.

# 11 - Power

---

Single phase and three phase, Transmission and distribution, Voltage regulation, Transformers, Motors and generators, Power factor (pf)



# Section 11.0 – Power

## Table of Contents

1.0	Introduction .....	3
2.0	Single vs. Three Phase .....	3
2.1	Apparent, Real, Reactive Power .....	3
2.2	Single-Phase .....	4
2.3	Three-Phase .....	5
2.4	Delta versus Wye Arrangements .....	7
2.4.1	Delta Arrangement .....	8
2.4.2	Wye Arrangement .....	9
2.4.3	Convert between Delta and Wye.....	10
2.5	Alternative Explanation of Delta & Wye .....	12
2.5.1	Wye Arrangement .....	13
2.5.2	Delta Arrangement .....	14
3.0	Power Factor .....	15
3.1	Waveform – Current & Voltage.....	15
3.2	Phasor – Current & Voltage.....	17
3.3	Power Triangle .....	19
4.0	Transmission and Distribution .....	21
4.1	Equivalent Circuits .....	21
4.1.1	Resistance.....	21
4.1.2	Inductance.....	24
4.1.3	Capacitance .....	24
4.1.4	Impedance.....	26
5.0	Voltage Regulation.....	26
6.0	Transformers .....	27
6.1	Types.....	27
6.2	Construction .....	28
6.3	Ideal transformers.....	28
6.4	Transforming Impedances.....	30
7.0	Motors and Generators .....	32
7.1	Construction of Synchronous Motor or Generator .....	32
7.2	Synchronous Speed .....	33



7.3	Synchronous Generator .....	34
7.4	Induction Motor or Generator .....	34
7.5	Slip.....	35
7.6	Speed-Torque.....	36
8.0	Practice Exam Problems.....	38
8.1	Practice Exam Problem 1 – Power Factor.....	38
8.2	Practice Exam Problem 2 – Reactive Power.....	38
8.3	Practice Exam Problem 3 – Three Phase .....	39
8.4	Practice Exam Problem 4 – Transformers.....	39
8.5	Practice Exam Problem 5 – Transformers.....	40
8.6	Practice Exam Problem 6 – Motors & Generators.....	40
8.7	Practice Exam Problem 7 – Motors & Generators.....	41
8.8	Practice Exam Problem 8 – Power Factor.....	41
8.9	Practice Exam Problem 9 – Single Phase .....	42
8.10	Practice Exam Problem 10 – Three Phase .....	42
8.11	Practice Exam Problem 11 – Transmission & Distribution .....	43
8.12	Practice Exam Problem 12 – Power Factor.....	43
9.0	Practice Exam Solutions .....	44
9.1	Practice Exam Solution 1 – Power Factor .....	44
9.2	Practice Exam Solution 2 – Reactive Power .....	44
9.3	Practice Exam Solution 3 – Three Phase.....	45
9.4	Practice Exam Solution 4 - Transformers.....	45
9.5	Practice Exam Solution 5 - Transformers.....	46
9.6	Practice Exam Solution 6 - Motors & Generators.....	47
9.7	Practice Exam Solution 7 - Motors & Generators.....	47
9.8	Practice Exam Solution 8 – Power Factor .....	48
9.9	Practice Exam Solution 9 – Single Phase .....	48
9.10	Practice Exam Solution 10 – Three Phase.....	49
9.11	Practice Exam Solution 11 – Voltage Regulation .....	50
9.12	Practice Exam Solution 12 – Power Factor .....	50



## 1.0 INTRODUCTION

Power accounts for approximately 8 to 12 questions on the Electrical FE exam. These questions cover single phase and three phase power. It also covers power factor and more specific power topics like the transmission and distribution of power and voltage regulation. In addition, this section covers power equipment like transformers, motors and generators.

The *NCEES FE Reference Handbook* Statics section has a section called AC power, which covers the subtopics: Complex Power, Balanced Three Phase Systems, Turns Ratio, AC Machines, DC Machines, Servomotors, Generators and Voltage Regulation. All of these topics are covered in this section. There is another power topic in the *NCEES FE Reference Handbook* called Maximum Power-Transfer Theorem, but this topic is covered in Section 7.0 Circuit Analysis.

Section 11.0 Power (8 to 12 Problems)		
NCEES Outline Value	Engineering Pro Guides Topic	
	Topic 1.0	Introduction
11A	Topic 2.0	Single vs. Three Phase
11F	Topic 3.0	Power Factor
11B	Topic 4.0	Transmission and Distribution
11C	Topic 5.0	Voltage Regulation
11D	Topic 6.0	Transformers
11E	Topic 7.0	Motors and Generators
	Topic 9.0	Practice Exam Problems

## 2.0 SINGLE VS. THREE PHASE

In power engineering, you will encounter both single-phase and three-phase circuits; you should be familiar with the differences in single-phase and three-phase for the exam. In application, single-phase is used for low power loads and/or short distances. Single-phase often powers residential loads, lighting loads, receptacles, small motors (less than 1 HP), office loads, etc. Three-phase is used for higher power loads and/or long distances. Three-phase is used for power generation, utility loads, transmission & distribution, larger motors (greater than 1 HP).

### 2.1 APPARENT, REAL, REACTIVE POWER

Before diving into single phase and three phase power, a brief introduction of the different types of power in AC circuits is provided below. A more detailed summary is given at the end of the Power Factor section.

**Apparent Power (S):** Apparent power, represented as the variable “S”, is the total power in an AC circuit. Apparent power is generally calculated as the RMS current times the RMS voltage.



This formula gets modified based on the number of phases available. Apparent power is given in units of VA (volts-amps).

**Real Power (P):** Real power is represented as the variable “P,” and is the usable power in a circuit, i.e. the power that can perform work. As discussed in Section 6.0 Engineering Sciences, real power is the power to resistive loads. Real power is given in units of W (watts).

**Reactive Power (Q):** Reactive power is the imaginary power in a circuit and is represented as “Q”. Reactive power is caused by inductors and capacitors that do not actually consume power, but stores voltage or energy in the circuit, which reduces the amount of actual power that can be used at the load. Reactive power is given in units of VAR (volts-amps reactive).

The relationship between apparent, real, and reactive power is shown in the vector diagram below, where the x-axis represents the real component and the y-axis represents the imaginary component.

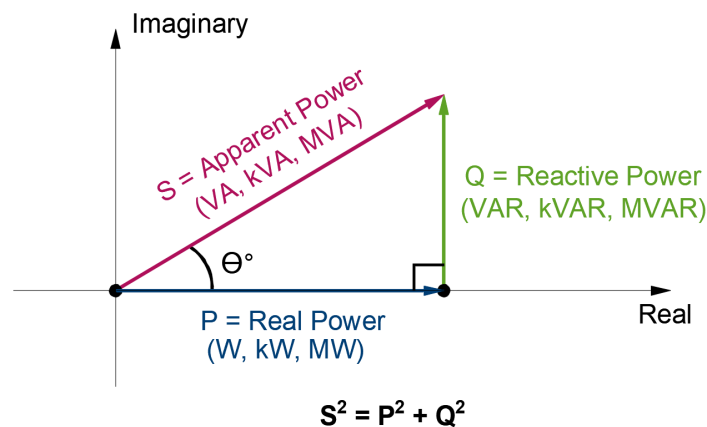

Figure 1: Relationship between apparent, real, and reactive power.

## 2.2 SINGLE-PHASE

A single-phase power circuit is shown on a circuit as having a single “hot” line and a return path “neutral” line. If you have done some electrical work in your house, then you should be familiar with single-phase power. In a home, electrical power is typically routed from the utility, which is shown as “AC” in the next diagram. A single wire, called the hot line, is routed to a power panel. This panel provides power to individual circuits that are protected with a circuit breaker. From the circuit breaker, a hot line is routed to a receptacle (load) and a neutral line is routed back to the panel and then continued back to the power source (AC), which completes the circuit.

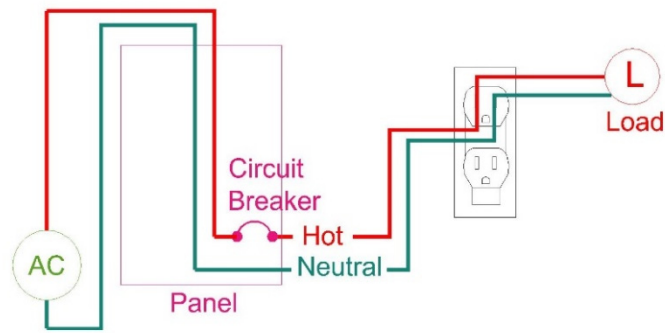

Figure 2: Single-phase circuit has a hot line and a neutral line.

Apparent power in a single phase circuit is calculated with the simple current times voltage equation. Remember that the voltage and currents are RMS values.

$$S = I * V$$

$S =$  Apparent Power (VA);  $I =$  current (amperes);  $V =$  voltage (volts);

Real power for single phase circuits is calculated by simply multiplying the current, voltage and power factor. Power factor will be discussed at the end of the Power Section. Briefly, power factor (PF) is the fractional amount of usable or real power. When PF=1, the power is 100% real or usable.

$$P = S * PF = I * V * PF$$

$P =$  real power (kW);  $I =$  current (amperes);  $V =$  voltage (volts);  $PF =$  power factor

## 2.3 THREE-PHASE

A three-phase power circuit has either three or four power wires. Three wires provide the three phases of power to a load and the fourth wire is sometimes used as a neutral to return unbalanced current back to the source. Three-phase power is used because of its efficiency in the amount of wires, versus the amount of power it can carry. In a single-phase circuit, you need 1 wire to provide the power and 1 wire to complete the circuit to carry the power back to the source. In a three-phase circuit, you have 3 wires (3 phases), each providing power and only 1 wire at most completing the circuit.

Three-phase power accomplishes this feat by using alternating current and the difference in frequencies to provide power to a load. Three wires with current traveling at the same alternating current frequency are offset by 120 degrees or 1/3 of their period. In order to illustrate this point, assume the total length of a period is 3 seconds, meaning that current reaches its positive peak at time 0 sec, then its negative peak at 1.5 sec and finally the end of its period at its positive peak at 3 sec. Now assume that the second phase or second wire starts at time 1 sec and its negative peak at 2.5 sec and the end of its period at 4 sec. The third wire starts at 2 sec and its negative peak is at 3.5 sec and the end of its period is at 5 sec.

# 12 - Electromagnetics

---

Maxwell equations, Electrostatics/magnetostatics (e.g., measurement of spatial relationships, vector analysis), Wave propagation, Transmission lines (high frequency), Electromagnetic compatibility





# Section 12.0 – Electromagnetics

## Table of Contents

1.0	Introduction .....	2
2.0	Maxwell Equations .....	2
2.1	Gauss' Law for Electricity .....	3
2.2	Gauss' Law for Magnetism .....	5
2.3	Faraday's Law of Induction .....	6
2.4	Ampere's Law .....	7
2.5	Right Hand Rules .....	9
2.5.1	Moving Charge .....	9
2.5.2	Current moving through a Wire .....	10
2.5.3	Current through Coil .....	10
3.0	Electrostatics/Magnetostatics .....	11
3.1	Coulomb's law .....	12
3.1.1	Point Charge .....	13
3.1.2	Line Charge .....	13
3.1.3	Sheet Charge .....	14
4.0	Wave Propagation .....	15
5.0	Transmission Lines .....	16
6.0	Electromagnetic Compatibility .....	18
7.0	Practice Exam Problems .....	19
7.1	Practice Exam Problem 1 – Electrostatics/Magnetostatics .....	19
7.2	Practice Exam Problem 2 – Electrostatics/Magnetostatics .....	19
7.3	Practice Exam Problem 3 – Maxwell Equations .....	19
7.4	Practice Exam Problem 4 – Maxwell Equations .....	20
7.5	Practice Exam Problem 5 – Maxwell Equations .....	20
7.6	Practice Exam Problem 6 – Transmission Lines .....	21
7.7	Practice Exam Problem 7 – Transmission Lines .....	21
7.8	Practice Exam Problem 8 – Transmission Lines .....	21
8.0	Practice Exam Solutions .....	22
8.1	Practice Exam Solution 1 – Electrostatics/Magnetostatics .....	22
8.2	Practice Exam Solution 2 - Electrostatics/Magnetostatics .....	22
8.3	Practice Exam Solution 3 – Maxwell Equations .....	23



8.4	Practice Exam Solution 4 – Maxwell Equations .....	23
8.5	Practice Exam Solution 5 – Maxwell Equations .....	24
8.6	Practice Exam Solution 6 – Transmission Lines .....	24
8.7	Practice Exam Solution 7 – Wave Propagation.....	25
8.8	Practice Exam Solution 8 – Transmission Lines .....	25

## 1.0 INTRODUCTION

Electromagnetics or electromagnetism accounts for approximately 5 to 8 questions on the Electrical FE exam. These questions can cover the Maxwell Equations, Electrostatics, Magnetostatics, Wave Propagation, Transmission Lines and Electromagnetic Compatibility. Electromagnetism is the study of the relationship between magnetism and electricity (current & voltage). Electromagnetism is important because this relationship serves as the basis for nearly all electric equipment like transformers, motors and generators.

The *NCEES FE Reference Handbook* has some basic equations for the topics below, but it does not explain the skills and concepts necessary to use these equations. You should learn the skills and concepts presented in this section and go through the handbook to confirm that you know how to use the basic equations.

Section 12.0 Electromagnetics (5 to 8 Problems)		
NCEES Outline Value	Engineering Pro Guides	
	Section 1.0	Introduction
12A	Section 2.0	Maxwell Equations
12B	Section 3.0	Electrostatics/Magnetostatics
12C	Section 4.0	Wave Propagation
12D	Section 5.0	Transmission Lines
12E	Section 6.0	Electromagnetic Compatibility
	Section 7.0	Practice Exam Problems

## 2.0 MAXWELL EQUATIONS

The Maxwell Equations are used to There are four Maxwell Equations.

- (1) Gauss' Law for Electricity
- (2) Gauss' Law for Magnetism
- (3) Faraday's Law of Induction
- (4) Ampere's Law

There are a few terms that you should understand before exploring the Maxwell Equations. The first is magnetic flux, which is described in units of Webers. Magnetic flux is the amount of magnetic field lines.

$$\Phi = \text{magnetic flux (Wb = Weber = } 1 \times 10^8 \text{ magnetic field lines)}$$

Magnetic flux density is the amount of magnetic flux per a unit area. The area must be perpendicular to the direction of flux. The equation for magnetic flux density is shown below.

$$B = \frac{\Phi}{\text{Area}}$$

$$B = \text{magnetic flux density (Tesla); } \Phi = \text{magnetic flux (Weber); } A = \text{area (m}^2\text{)}$$

The strength of a magnetic field in a coil of wire depends on how much current flows in the turns of the coil. The more current, the stronger the magnetic field. Also, the more turns, the more concentrated are the lines of force. The product of the current times the number of turns of the coil, which is expressed in units called ampere-turns (At), is known as the magneto-motive force. As a formula,

$$F = N * I$$

$$F = \text{ampere turns, } N = \text{turns; } I = \text{current (amps)}$$

The Maxwell equations are presented in the FE Reference Handbook, but the versions of the equations are not useful for solving the problems on the exam. These next sections will translate those versions in the handbook to more useful versions that you can use on the exam. You should go through these translations, so you can remember what the equations shown in the handbook mean in practical and useful terms.

## 2.1 GAUSS' LAW FOR ELECTRICITY

The first Maxwell equation is Gauss' Law for Electricity. The version of the law shown in the FE Reference Handbook is shown in the equation below.

$$\text{Gauss' Law for Electric Fields (Integral Form)} \rightarrow \oiint_{S_V} D \cdot dS = \iiint_V \rho dv$$

The left hand side of this equation calculates the sum of all the "D" electric flux lines that are entering and exiting the surface of some volume. The right hand side of the equation calculates the total electric charge in a volume. The left hand side of the equation will result in the units Coulomb and so will the right hand side of the equation. You should also see that on the left hand side of the equation the "D" or electric flux is multiplied by an area (m<sup>2</sup>). So you can deduce that the units of electric flux are C/m<sup>2</sup>.

The next equation is the differential form of the same integral equation.

$$\text{Gauss' Law for Electric Fields (Differential Form)} \rightarrow \nabla \cdot D = \rho$$

$D = \text{Electric flux } (C/m^2)$ ;  $\nabla = \text{divergence operator}$ ;  $\rho = \text{electric charge density}$ ;

The divergence vector says a similar thing as the previous left side of the equation. It calculates the “D” electric flux lines that are leaving a point. The right hand side of the equation is the total electric charge.

Electric flux is the rate at which the electric field flows through a given area. The electric field is the area around a charge or the area between a voltage potential. The greater the charge or the greater the voltage potential, then the greater the electric field. Electric flux will also depend on the way the area is drawn and the math can get a little complicated, but for the purposes of this FE exam, you should not need anything more than the equations shown in this section and in the NCEES FE Reference Handbook.

Electric flux is related to electric field intensity through the following equation. This equation introduces the permittivity of free space or simply permittivity. This is a constant that defines the ability of a medium to promote electric fields. The permittivity shown in the NCEES FE Reference Handbook is for air or free space. It has units of Farad per meter, which can also be shown as Coulomb per volt-meter.

$$D = \epsilon_0 E$$

$E = \text{electric field intensity } \left(\frac{V}{m}\right)$ ;  $\epsilon_0 = \text{permittivity constant } 8.85 \times 10^{-12} (F/m)$

$$\text{Derivation of Units of } D \rightarrow \epsilon_0 E = \left(\frac{F}{m}\right) \left(\frac{V}{m}\right) = \left(\frac{C}{v-m}\right) \left(\frac{V}{m}\right) = \frac{C}{m^2}$$

The useful equation that you should use on the exam is shown below. This equation can be used for various conditions like an enclosed point charge, an enclosed line charge and an enclosed sheet charge. This is discussed more in Coulomb’s law in this section.

$$\oint_S E \cdot \hat{n} dA = \frac{Q_{\text{enclosed}}}{\epsilon_0}$$

$E = \text{electric field vector } \left(\frac{V}{m}\right)$ ;  $Q_{\text{enclosed}} = \text{enclosed charge } (C)$ ;

This equation says that a charge will produce an electric field and the sum of the electric field intensity across an area will be equal to the enclosed charge divided by the permittivity. The units for permittivity can also be rewritten as Coulomb per Volt-Meter. This will result in the units of volt per meter for the division of the enclosed charge by the permittivity.

$$\text{Derivation of Units of } E \rightarrow \frac{Q_{\text{enclosed}}}{(\text{Area})\epsilon_0} = \left(\frac{C}{F/m}\right) = \left(\frac{C}{\left(\frac{C}{v-m}\right)m^2}\right) = \frac{V}{m}$$



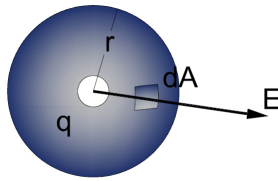

Figure 1: This figure shows a charge enclosed by an area. The resulting electric field can be found in units, volt per meter.

Basically, Gauss's law for electricity states that an electric charge will either attract or repel electric field lines. The intensity of electric field lines will be in direct proportion to the quantity of the charge. The intensity of electric field lines will be inversely proportional to the surface area in question.

## 2.2 GAUSS' LAW FOR MAGNETISM

The second Maxwell equation is Gauss Law for Magnetism. The version of the law shown in the FE Reference Handbook is shown in the equation below.

$$\text{Gauss' Law for Magnetic Fields (Integral Form)} \rightarrow \oiint_{S_V} B \cdot dS = 0$$

The left hand side of the equation describes taking the integral of a magnetic flux over a length or surface. The special integral symbol reminds you that this integral is over a closed surface. The dot product between the electric field and the incremental change in length or surface is to show that the magnetic flux lines must be perpendicular to the surface or length. The right hand side of the equation is equal to zero, because there is no magnetic charge density.

$$B = \text{magnetic flux (Tesla or } \frac{\text{Weber}}{\text{meter}^2}\text{)}$$

The next equation is the differential form of the same equation. Again, there is no such thing as a magnetic charge density, so unlike the first Gauss's law which had the electric flux equal to the electric charge density, there is no magnetic charge density, so the right side is equal to 0. Another way to think about the reason for the zero is that magnets always have a north and south pole or a positive and negative side, so the positive and negative sides are equal in magnitude but opposite in sign, thus the sum of the magnetic flux must be equal to zero.

$$\text{Gauss' Law for Magnetic Fields (Differential Form)} \rightarrow \nabla \cdot B = 0$$

Magnetic flux is related to magnetic field strength (intensity) through the following equation. This equation introduces the permeability of free space or simply permeability. This is a constant that defines the ability of a medium to promote magnetic fields. The permeability shown in the NCEES FE Reference Handbook is for air or free space. It has units of Henries per meter, which can also be shown as Newton per ampere squared.

$$B = \mu H$$

# 13 – Control Systems

---

Block diagrams (feed-forward, feedback), Bode plots, Closed-loop and open-loop response, Controller performance (gain, PID), steady-state errors, Root locus, Stability, State variables



# Section 13.0 – Control Systems

## Table of Contents

1.0	Introduction .....	2
2.0	Block Diagrams .....	3
2.1	Functions in Series .....	3
2.2	Functions in Parallel .....	4
2.3	Functions with Feedback Loop .....	4
3.0	Bode Plots .....	5
3.1	Bode Magnitude Plot .....	5
3.2	Bode Phase Plot .....	6
3.3	Sketching Bode Plots .....	6
3.3.1	Step 1 - Formatting .....	6
3.3.2	Step 2 - Determine the Poles, Zeros and Constants .....	6
3.3.3	Step 3 - Draw the Bode Diagram Parts .....	7
3.3.4	Step 4 - Combine Bode Diagram Parts .....	9
4.0	Closed-Loop and Open-Loop Response .....	11
4.1	Routh Test .....	11
4.2	Steady State Error .....	13
4.2.2	Type 0 Example .....	14
4.2.2	Type 1 Example .....	15
4.2.3	Type 2 Example .....	15
5.0	Controller Performance .....	16
5.1	Proportional Control .....	17
5.2	Integral Control .....	17
5.3	Derivative Control .....	18
6.0	Root Locus .....	18
6.1	Step 1: Formatting .....	18
6.2	Step 2: Number of Poles and Zeroes .....	19
6.3	Step 3: Draw Poles, Zeros & Locus Lines .....	19
7.0	Stability .....	23
7.1	Gain Margin .....	23
7.2	Phase Margin .....	26
8.0	State Space Model .....	29



8.1	Convert to State Space .....	30
9.0	Practice Exam Problems.....	31
9.1	Practice Exam Problem 1 – Routh Test .....	31
9.2	Practice Exam Problem 2 – Block Diagram.....	31
9.3	Practice Exam Problem 3 - Bode Plot .....	32
9.4	Practice Exam Problem 4 – Bode Plot .....	32
9.5	Practice Exam Problem 5 – Root Locus.....	33
9.6	Practice Exam Problem 6 – Root Locus.....	34
9.7	Practice Exam Problem 7 – Steady State Error.....	35
9.8	Practice Exam Problem 8 – Steady State Error.....	35
10.0	Practice Exam Solutions .....	36
10.1	Practice Exam Solution 1 – Routh Test.....	36
10.2	Practice Exam Solution 2 – Block Diagram .....	37
10.3	Practice Exam Solution 3 – Bode Plot.....	38
10.4	Practice Exam Solution 4 – Bode Plot.....	40
10.5	Practice Exam Solution 5 – Root Locus .....	41
10.6	Practice Exam Solution 6 – Root Locus .....	42
10.7	Practice Exam Solution 7 – Steady State Error .....	43
10.8	Practice Exam Solution 8 – Steady State Error.....	43

## 1.0 INTRODUCTION

Control Systems accounts for approximately 6 to 9 questions on the Electrical FE exam. These questions can cover block diagrams, bode plots, closed/open loop responses, controller performance, steady state errors, root locus, stability and state variables.

The *NCEES FE Reference Handbook* has a section called Communication Theory and Concepts that is included as part of the Electrical and Computer Engineering chapter. This section is primarily used in Section 14 Communications. However, this area in the FE handbook also covers several bode plots corresponding to common functions, which will also be covered in this section. This will help to jog your memory when asked about bode plots. Bode plots are needed in control systems. The majority of the Control Systems topics in the FE Handbook will be found in the Instrumentations, Measurement and Controls chapter. You will need everything in this section, like the Routh test, transfer function models, steady state error, frequency response, root-locus and control models. There is some overlap with the Laplace Transform from the Mathematics chapter in the FE Handbook, but the Laplace transform was covered in Section 8 Linear Systems.



## Section 13.0 Control Systems (6 to 9 Problems)

NCEES Outline Value	Engineering Pro Guides	
	Section 1.0	Introduction
13A	Section 2.0	Block Diagrams (feed-forward, feedback)
13B	Section 3.0	Bode Plots
13C	Section 4.0	Closed-Loop and Open-Loop Response
13D	Section 5.0	Controller Performance (gain, PID), Steady-State Errors
13E	Section 6.0	Root Locus
13F	Section 7.0	Stability
13G	Section 8.0	State Variables
	Section 9.0	Practice Exam Problems

## 2.0 BLOCK DIAGRAMS

Block diagrams are used to diagrammatically show a control system. Each block contains either an input variable or a function that processes a variable.

### 2.1 FUNCTIONS IN SERIES

If two functions are in series, then the functions can be simplified by multiplying them together.

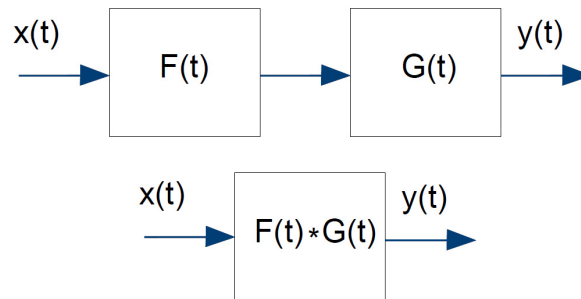

*Figure 1: This block diagram shows an input function “ $x(t)$ ” entering a control function called “ $F(t)$ ”. Then the output from  $F(t)$  enters another function called  $G(t)$ . The final output is shown as  $y(t)$ . The two functions,  $F(t)$  and  $G(t)$  can be simplified by multiplying the two functions together.*

The block diagram of two functions in series can be simplified into the equation format shown below.

$$\frac{y(t)}{x(t)} = F(t) * G(t)$$

## 2.2 FUNCTIONS IN PARALLEL

If the functions are in parallel, then you can add the two functions.

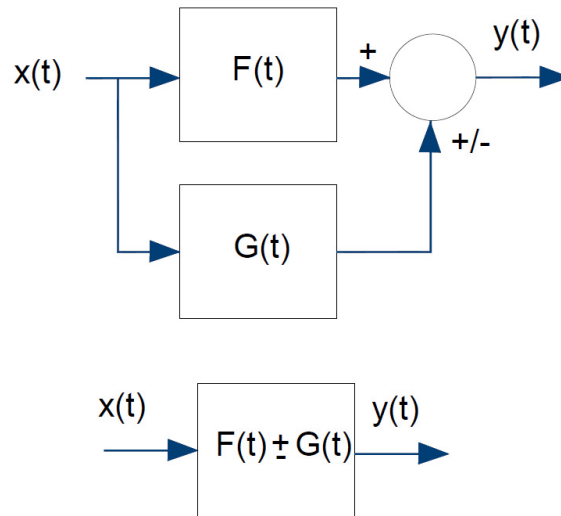

Figure 2: If two functions are arranged in parallel, then the two functions can be simplified by adding the two functions together.

The block diagram of two functions in parallel can be simplified into the equation format shown below.

$$\frac{y(t)}{x(t)} = F(t) \pm G(t)$$

## 2.3 FUNCTIONS WITH FEEDBACK LOOP

If the group of functions are arranged to have a feedback loop, then you can simplify the blocks as shown in the below process. In order to simplify the feedback loop, you need to assign an intermediary function  $B(t)$ .

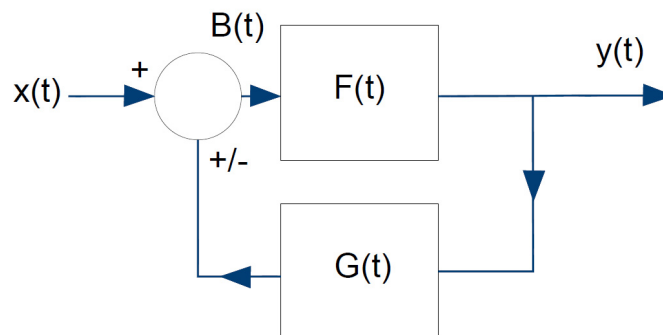

Figure 3: This figure shows a function  $x(t)$  that is processed by function  $F(t)$ , but the output from  $F(t)$  is processed through  $G(t)$ , which is fed back to the  $x(t)$ . This is called a feedback loop.

# 14 - Communications

---

Basic modulation/demodulation concepts (e.g., AM, FM, PCM), Fourier transforms/Fourier series, Multiplexing (e.g., time division, frequency division), Digital communications



# Section 14.0 – Communications

## Table of Contents

p1.0	Introduction .....	2
2.0	Fourier Transforms/Fourier Series .....	3
2.1	Common Fourier Transform Pairs .....	4
2.1.1	Delta Function .....	4
2.1.2	Step Function .....	5
2.1.3	Square Impulse (Box) Function .....	6
2.1.4	Triangle Function.....	6
2.1.5	Decaying Exponential Function.....	7
2.1.6	Cosine Function .....	8
2.1.7	Sine Function .....	8
2.2	Fourier Transform Properties .....	9
2.2.1	Linearity.....	9
2.2.2	Time and Frequency Shifting .....	9
2.2.3	Time Scaling.....	10
2.2.4	Time Differentiation & Time Integration.....	10
2.2.5	Convolution .....	10
2.3	Signal Energy .....	11
2.3.1	Parseval's Theorem .....	11
3.0	Basic Modulation/Demodulation Concepts .....	12
3.1	Amplitude Modulation .....	12
3.1.1	Double Sideband Modulation, Suppressed Carrier .....	16
3.1.2	Single Sideband Modulation, Suppressed Carrier .....	18
3.2	Angle Modulation.....	18
3.2.1	Frequency Modulation.....	19
3.2.2	Phase Modulation.....	20
4.0	Multiplexing .....	22
4.1	Time Division .....	23
4.2	Frequency Division .....	23
5.0	Digital Communications .....	23
5.1	Pulse Width Modulation.....	23
5.2	Pulse Amplitude Modulation .....	26



6.0	Practice Exam Problems.....	27
6.1	Practice Exam Problem 1 – Fourier Transform .....	27
6.2	Practice Exam Problem 2 – Fourier Transform .....	27
6.3	Practice Exam Problem 3 – Fourier Transform .....	28
6.4	Practice Exam Problem 4 – Amplitude Modulation .....	28
6.5	Practice Exam Problem 5 – Phase Modulation .....	29
6.6	Practice Exam Problem 6 – Frequency Modulation .....	29
7.0	Practice Exam Solutions .....	30
7.1	Practice Exam Solution 1 – Fourier Transforms.....	30
7.2	Practice Exam Solution 2 – Fourier Transforms.....	31
7.3	Practice Exam Solution 3 – Fourier Transforms.....	31
7.4	Practice Exam Solution 4 – Amplitude Modulation.....	32
7.5	Practice Exam Solution 5 – Phase Modulation.....	33
7.6	Practice Exam Solution 6 – Frequency Modulation.....	34

## 1.0 INTRODUCTION

Communications accounts for approximately 5 to 8 questions on the Electrical FE exam. These questions can cover modulation and demodulation which is the majority of most communications college class. In addition Fourier Transforms and Fourier series are referenced in this section too. Fourier is also referenced in the Signal & Processing section. The last two topics, Multiplexing and Digital Communications are briefly covered in the FE Reference Handbook, which may indicate that there will not be as many computational type problems on these topics.

The *NCEES FE Reference Handbook* section has the main equations for the basic modulation/demodulation skills learned in a basic Communications or Signals college class, however the equations are not as user friendly and so you should have the user friendly and graphical approach to these types of problems memorized. These equations are located in the Electrical & Computer Engineering section of the handbook.

Section 14.0 Communications (5 to 8 Problems)		
NCEES Outline Value	Engineering Pro Guides	
	Section 1.0	Introduction
14A	Section 2.0	Basic modulation/demodulation concepts (e.g., AM, FM, PCM)
14B	Section 3.0	Fourier transforms/Fourier series
14C	Section 4.0	Multiplexing (e.g., time division, frequency division)
14D	Section 5.0	Digital communications

## 2.0 FOURIER TRANSFORMS/FOURIER SERIES

The Fourier Transform is used to transform an equation from being a function of time to being a function of frequency and vice versa. This transform is used heavily in this Communications section and the Signal Processing section. The reference for this topic is located in the Mathematics section of the NCEES FE Reference Handbook.

The following equation is used to convert a time dependent function “ $f(t)$ ” to a frequency dependent equation.

$$\text{Frequency Dependent Equation} \rightarrow F(w) = \int_{-\infty}^{\infty} f(t)e^{-jwt} dt$$

The following equation is used to convert a frequency dependent function “ $F(w)$ ” to a time dependent equation.

$$\text{Time Dependent Equation} \rightarrow f(t) = \frac{1}{2\pi} \int_{-\infty}^{\infty} F(w)e^{jwt} dt$$

The purpose of the Fourier transform in communications is that you can take complex, time based signals and convert them to a sum of sinusoidal based functions with different frequencies and different amplitudes. Once transformed, the functions can be sent through filters to extract all the important information. On the FE exam, you should be familiar with the typical Fourier Transforms shown in table format in the NCEES FE Reference Handbook. This section and the practice problems will take you through several Fourier Transforms and Inverse Fourier Transforms to help you get these problems correct on the actual exam.

$$x(t) = \sum_{n=-\infty}^{n=+\infty} X_n e^{jn2\pi f_0 t}$$

The following two figures shows graphically how a sinusoid can be shown in the time domain or in the frequency domain.

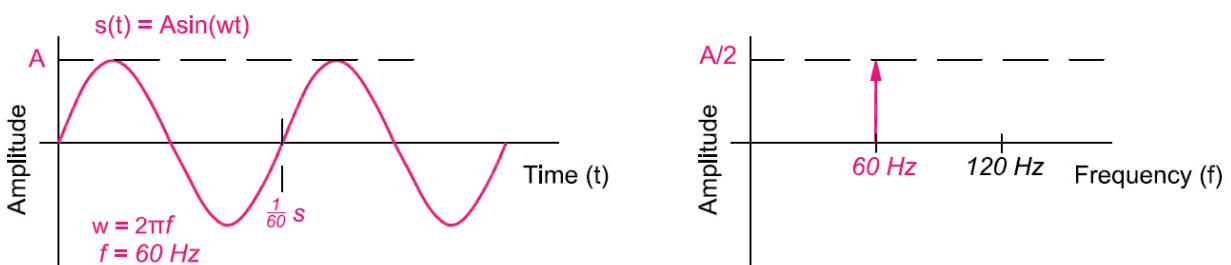

Figure 1: Signals can be represented in the time domain or the frequency domain. This figure shows a 60 Hz signal with amplitude  $A$ . In the time domain, the signal is shown with a period of  $1/60$  seconds and an amplitude of “ $A$ ”. In the frequency domain, the signal is shown as a single line at 60 Hz, with an amplitude of “ $A$ ”.

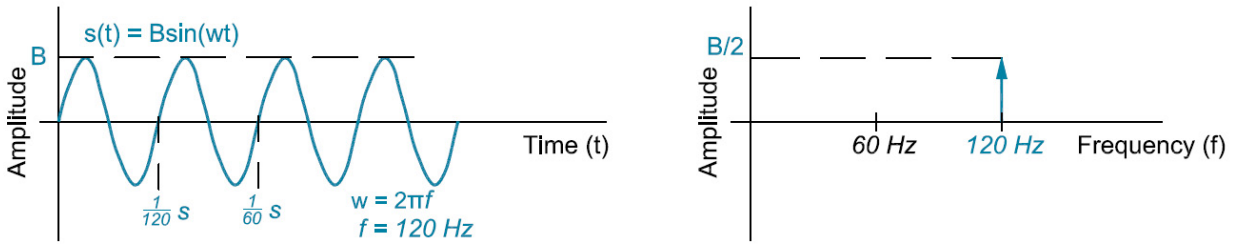

Figure 2: This figure shows a 120 Hz signal with amplitude B. In the time domain, the signal is shown with a period of 1/120 seconds and an amplitude of “B”. In the frequency domain, the signal is shown as a single line at 120 Hz, with an amplitude of “B”.

## 2.1 COMMON FOURIER TRANSFORM PAIRS

This section goes through all of the transform pairs presented in the book and helps to provide more background information on the pairs, so that you can better use the FE Handbook during the exam.

### 2.1.1 Delta Function

The first two pairs, revolve around the delta function. The delta function in the time domain is the function defined as equaling infinity at time  $t = 0$  and 0 everywhere else.

$$x(t) = \delta(t) = \begin{cases} +\infty, & t = 0 \\ 0, & t \neq 0 \end{cases}$$

The Fourier transform of this function is equal to just the amplitude applied to the delta function.

$$\text{Taking the Fourier Transform of the Function} \rightarrow F\{\delta(t)\} = X(f) = 1$$

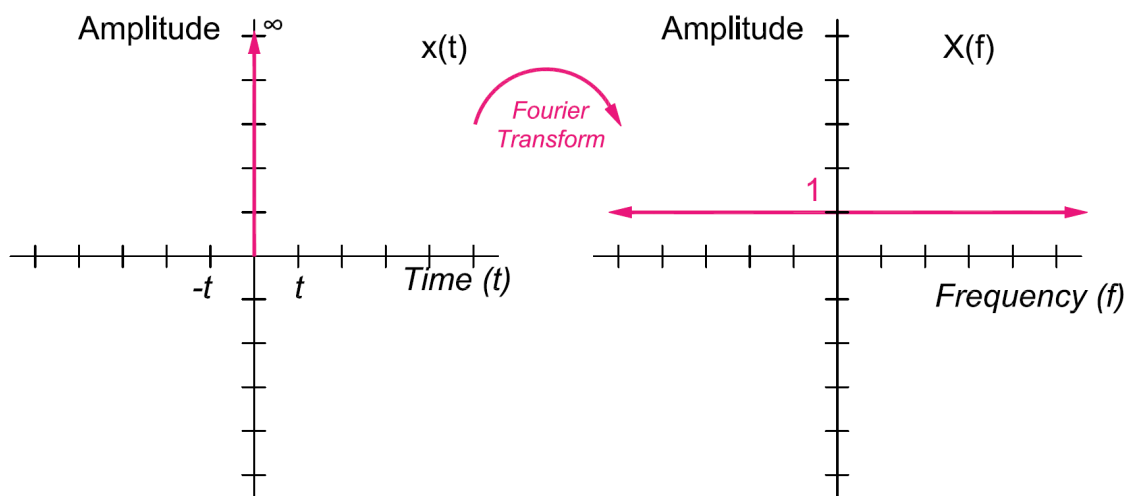

Figure 3: The Fourier transform of the delta function is equal to 1 at all frequencies.

The Fourier transform of an amplitude 1 will equal the delta function.

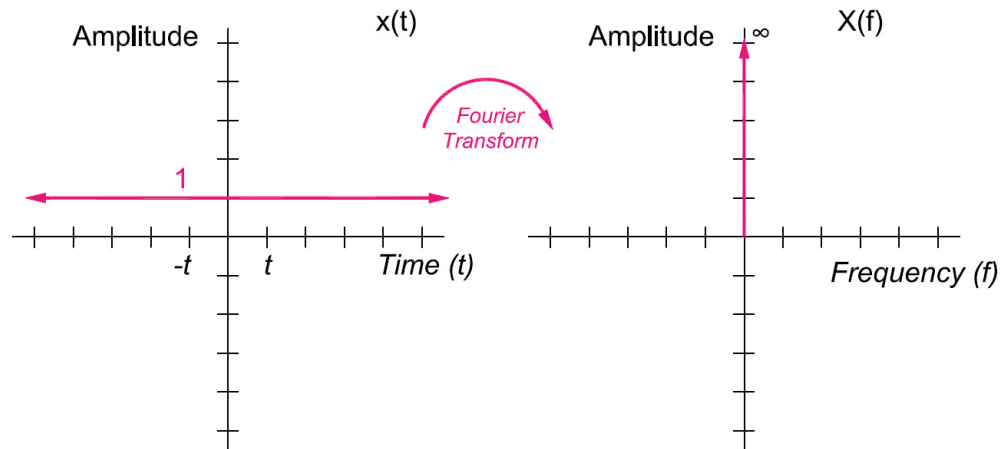

Figure 4: The Fourier transform of a constant will equal the delta function.

$$F\{1\} = X(f) = \delta(f)$$

### 2.1.2 Step Function

The next Fourier transform pair is the step function. The step function builds off of the delta function. A step function is defined as equal to 1 at all times after  $t = 0$ . But you can rewrite this equation by shifting it down by 0.5. Now the function consists of a constant of 0.5 at times  $t$  greater than 0 and a constant of -0.5 at times  $t$  less than 0. This results in the Fourier transform that consists of 0.5 of the delta function and an imaginary frequency term.

$$\text{Time Function} \rightarrow u(t) = \begin{cases} 1, & t \geq 0 \\ 0, & t < 0 \end{cases} = \begin{cases} 0.5, & t \geq 0 \\ -0.5, & t < 0 \end{cases}$$

$$\text{Frequency Function} \rightarrow L\{x(t)\} = X(f) = 0.5\delta(t) + \frac{1}{j2\pi f}$$

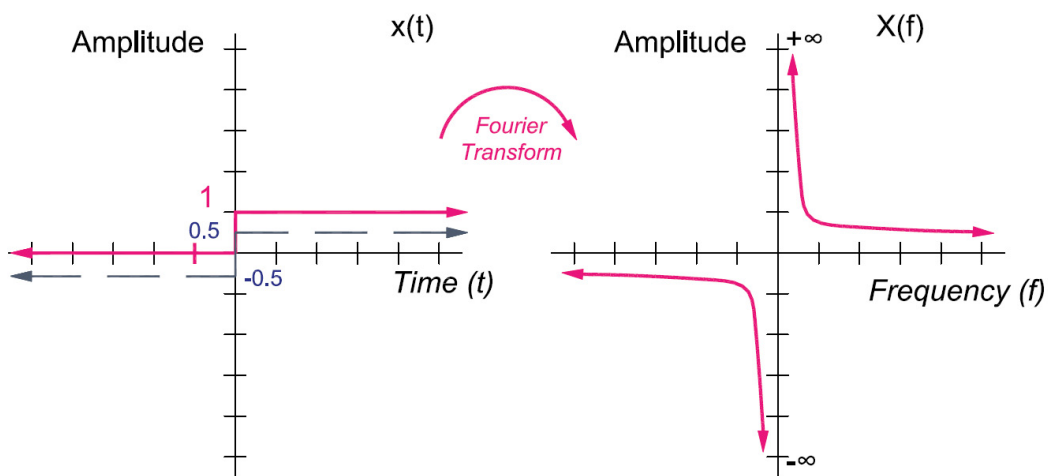

Figure 5: The Fourier Transform of the step function will consist of the positive and negative delta functions at  $f = 0$ . Please remember the imaginary component. The amplitudes are of the



# 15 – Computer Networks

---

Routing and switching, Network topologies/frameworks/models, Local area networks



# Section 15.0 – Computer Networks

## Table of Contents

1.0	Introduction .....	2
2.0	Routing and Switching .....	2
2.1	TCP/IP Model .....	3
2.2	OSI Model.....	3
3.0	Network Topologies/Frameworks/Models .....	4
3.1	Point to Point .....	4
3.2	Token Ring .....	4
3.3	Bus .....	5
3.4	Star .....	5
3.5	Mesh.....	6
3.6	Tree .....	6
4.0	Local Area Networks .....	7
4.1	Dynamic Host Configuration Protocol (DHCP) .....	7
4.2	Static IP .....	8
4.3	Stateless Address Auto Configuration (SLAAC).....	8
5.0	Error Coding.....	8
6.0	Delays in Computer Networks.....	9
6.1	Transmission Delay .....	9
6.2	Propagation Delay .....	9
6.3	Queuing Delay.....	10
6.4	Processing Delay.....	10
7.0	Automatic Request for Retransmission (ARQ).....	10
7.1	Stop & Wait.....	10
7.2	Go Back.....	11
7.3	Selective Repeat .....	11
8.0	Shannon Channel Capacity Formula .....	11
9.0	Cryptosystems .....	12
9.1	RSA Public-Key Cryptosystem .....	12
9.2	Diffie-Hellman Key-Exchange Protocol .....	13
10.0	Practice Exam Problems.....	15
10.1	Practice Exam Problem 1 - Diffie-Hellman Key Exchange .....	15



10.2	Practice Exam Problem 2 - Shannon Channel Capacity Formula .....	15
10.3	Practice Exam Problem 3 – Network Topologies .....	16
10.4	Practice Exam Problem 4 – Routing and Switching .....	16
10.5	Practice Exam Problem 5 – Local Area Networks .....	17
11.0	Practice Exam Solutions .....	18
11.1	Practice Exam Solution 1 – Diffie-Hellman Key Exchange Protocol.....	18
11.2	Practice Exam Solution 2 – Shannon Channel Capacity Formula.....	18
11.3	Practice Exam Solution 3 – Network Topologies.....	19
11.4	Practice Exam Solution 4 – Routing and Switching.....	20
11.5	Practice Exam Solution 5 – Local Area Networks .....	20

## 1.0 INTRODUCTION

Computer Networks accounts for approximately 3 to 5 questions on the Electrical FE exam. These questions can cover routing, switching, network topologies, frameworks, models and local area networks.

The *NCEES FE Reference Handbook* has about two pages on computer networks. There are a few equations within these pages, but the equations are vague and it may be difficult to imagine a problem using those equations. However, this section will explain in more detail the subtopics from the NCEES outline, in order to supplement the information that is presented in the handbook. This section will give examples and insight into the type of questions that can be asked on these subtopics. It is unlikely that the answers to the actual FE exam problems will be a simple look-up into the two pages on computer networks. You will most likely need a deeper understanding of the topics to answer these questions.

Section 15.0 Computer Networks (3 to 5 Problems)		
NCEES Outline Value	Engineering Pro Guides	
	Section 1.0	Introduction
15A	Section 2.0	Routing and Switching
15B	Section 3.0	Network Topologies/Frameworks/Models
15C	Section 4.0	Local Area Networks
	Section 5.0	Practice Exam Problems

## 2.0 ROUTING AND SWITCHING

The routing and switching topic in the NCEES outline does not have any subtopics, but based on what is included in the NCEES FE Reference Handbook, you can deduce that this topic will

cover the following subtopics (1) Transmission Control Protocol/Internet Protocol (TCP/IP) Model and (2) Open System Interconnect (OSI) Model. These two models describe how communications occur over the internet. Generally, information is disassembled and sent over the internet from one device to the next and at the receiving device that information is reassembled.

The first model, TCP/IP, is the one most commonly used in development and practice, while the OSI model is more conceptual.

## 2.1 TCP/IP MODEL

In this model there are four main layers, the Application, Transport, Network and Physical layers. From the host's perspective, you will start at the physical layer. The Physical layer instructs how data is physically sent across the network. This layer can also be called link or network interface. This is the method that connects the host to the network. Next, the network layer can also be called the internet layer. This layer will process packets and connects computers to one another. In this layer, you will see IP protocols, IP addressing, etc. The transport layer controls the flow and maintains reliability of the flow of information across the network. The transport layer will breakdown the data packets and label the data. Lastly, the application layer is where the data is presented to the receiver. In this layer, there will be protocols like FTP, HTTP and HTTPS.

TCP/IP Model
Application
Transport
Network
Physical

## 2.2 OSI MODEL

The OSI model is a newer model and it provides more detail than the TCP/IP model. Again, starting from the host, the host will connect to the network at the physical layer. The data link layer formats the data. The network layer will also conduct addressing, similar to the TCP/IP model. The transport layer again controls the flow of data, so it makes sure that data is traveling in the correct order. This is the TCP portion of the TCP/IP model. The network layer is the IP portion of the TCP/IP model. The session layer controls the communication back and forth between the presentation layer and the transport layer. Data must travel both ways. The presentation layer will decode aka translate the data for use or for sending. The application layer provides the receiver a way to access the data.

OSI Model	TCP/IP Model
Application	Application
Presentation	
Session	
Transport	Transport
Network	Network
Data Link	Physical
Physical	

### 3.0 NETWORK TOPOLOGIES/Frameworks/Models

The NCEES FE Reference Handbook has the following network models in graphical format with short descriptions, (1) Point to Point, (2) Token Ring, (3) Bus, (4) Star, (5) Mesh and (6) Tree. The problems that involve these network models will probably be a little bit more complex than the information given in the handbook. You should have an understanding of the basics of each model and the advantages/disadvantages of each model, which is explained in the next set of paragraphs.

#### 3.1 POINT TO POINT

The first network topology is the simplest method, called Point to Point. In this method, there is a direct connection between two terminals. A variation of this method is the Multipoint or Bus method. An example of a point to point connection is a computer hard wired to a printer or to a monitor. Two computers could also be directly connected via a terminal. The connection does not need to be permanent and can be temporary.

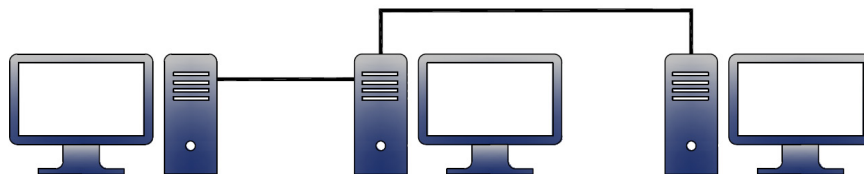

Figure 1: In the point to point network, computers are connected directly to each other.

#### 3.2 TOKEN RING

A token ring network topology uses multi-access point units (MAUs) to pass a token in a ring between the MAUs. When a computer wants to send information, it will request the token and then take the token. When a computer is using the token, then no other computer can send information. The computer will then send the information with an address corresponding to the desired receiving computer. After the information has been received, then the token will be released for another computer to use.

# 16 – Digital Systems

---

Number systems, Boolean logic, Logic gates and circuits, Logic minimization (e.g., SOP, POS, Karnaugh maps), Flip-flops and counters, Programmable logic devices and gate arrays, State machine design, Data path/controller design, Timing (diagrams, asynchronous inputs, races, hazards)



# Section 16.0 – Digital Systems

## Table of Contents

1.0	Introduction .....	3
2.0	Number Systems.....	4
2.1	Convert Decimal (Integers) to Binary .....	4
2.1.1	Using Your Ti-36 Pro.....	4
2.2	Convert Binary to Decimal (integers).....	5
2.2.1	Using Your Ti-36 Pro.....	5
2.3	Convert Decimal (Fractions) to Binary.....	6
2.4	Convert Binary to Decimal (Fractions).....	7
2.5	Convert Decimal (Integers) to Hexadecimal.....	7
2.5.1	Using Your Ti-36 Pro.....	8
2.6	Convert Hexadecimal to Decimal (Integers).....	8
2.5.1	Using Your Ti-36 Pro.....	9
3.0	Boolean Logic .....	9
3.1	Idempotent Law .....	10
3.2	Associative Law .....	10
3.3	Commutative Law.....	10
3.4	Distributive Law .....	10
3.5	Identity Law .....	10
3.6	Complement Law.....	11
3.7	DeMorgan's Law.....	11
3.8	Absorptive Law .....	11
4.0	Logic Gates and Circuits .....	12
5.0	Logic Minimization.....	13
5.1	Sum of Products (SOP) .....	13
5.2	Product of Sums (POS).....	14
5.3	Karnaugh Maps (K-Maps) .....	15
5.3.1	K-Map 3 Variables - SOP .....	16
5.3.2	K-Map 3 Variables – POS .....	17
5.3.3	K-Map 4 Variables – SOP & POS .....	18
6.0	Flip-Flops and Counters.....	19
6.1	NAND Latch.....	19



6.1.1	Normal Condition ( $S = 1, R = 1$ ) .....	19
6.1.2	Set Condition ( $S = 0, R = 1$ ) .....	20
6.1.3	Reset Condition ( $R = 0, S = 1$ ) .....	21
6.1.4	Invalid Condition ( $R = 0, S = 0$ ) .....	22
6.2	NOR Latch .....	23
6.3	SR (Set Reset) Flip Flop .....	24
6.2	JK Flip Flop .....	26
6.3	D Flip Flop .....	27
7.0	Programmable Logic Devices and Gate Arrays .....	28
8.0	State Machine Design .....	29
9.0	Data Path/Controller Design .....	31
10.0	Timing .....	31
10.1	Timing Diagrams .....	31
10.2	Timing Asynchronous vs. Synchronous Inputs .....	31
10.3	Timing Races and Hazards .....	31
11.0	Practice Exam Problems .....	32
11.1	Practice Exam Problem 1 – Number Systems .....	32
11.2	Practice Exam Problem 2 – Number Systems .....	32
11.3	Practice Exam Problem 3 – Boolean Logic .....	33
11.4	Practice Exam Problem 4 – Boolean Logic .....	33
11.5	Practice Exam Problem 5 – K-Map .....	34
11.6	Practice Exam Problem 6 – K Map .....	34
11.7	Practice Exam Problem 7 – K Map .....	35
11.8	Practice Exam Problem 8 – Flip Flop .....	35
11.9	Practice Exam Problem 9 – Flip Flop .....	36
11.10	Practice Exam Problem 10 – State Machine .....	36
11.11	Practice Exam Problem 11 – State Machine .....	37
12.0	Practice Exam Solutions .....	38
12.1	Practice Exam Solution 1 – Number Systems .....	38
12.2	Practice Exam Solution 2 – Number Systems .....	38
12.3	Practice Exam Solution 3 - Boolean Logic .....	39
12.4	Practice Exam Solution 4 – Boolean Logic .....	39
12.5	Practice Exam Solution 5 – K-Map .....	40
12.6	Practice Exam Solution 6 – K-Map .....	41





12.7	Practice Exam Solution 7 – K-Map.....	42
12.8	Practice Exam Solution 8 – Flip Flop.....	43
12.9	Practice Exam Solution 9 – Flip Flop.....	44
12.10	Practice Exam Solution 10 – State Machine.....	44
12.11	Practice Exam Solution 11 – State Machine.....	45

## 1.0 INTRODUCTION

Digital Systems accounts for approximately 7 to 11 questions on the Electrical FE exam. The NCEES FE Electrical & Computer Engineering Outline covers nearly all the topics from a Digital Systems class in college. The topics range from the first part of a normal college class, which would include number systems, Boolean logic in algebraic form and gate/circuit form. Also included in the outline are flip flops, counters, programmable logic devices, gate arrays, state machine design, data controller design and timing. Even though all these topics are included in the outline, the questions will most likely revolve around the topics that are easier to test. For insight into what is easier to test, you should refer to the NCEES FE Reference Handbook.

The *NCEES FE Reference Handbook* section on Digital Systems is located in the Electrical and Computer Engineering section. It covers number systems, logic operations (gate/circuit form), flip flops and Karnaugh maps. You can see that many of the outline topics are not included in the handbook, which seems to indicate that the other outline topics will be less of a focus on the actual exam. This section will still discuss those topics but you should keep this discussion in mind, when reviewing those topics.

Section 16.0 Digital Systems (7 to 11 Problems)		
NCEES Outline Value	Engineering Pro Guides	
	Section 1.0	Introduction
16A	Section 2.0	Number systems
16B	Section 3.0	Boolean logic
16C	Section 4.0	Logic gates and circuits
16D	Section 5.0	Logic minimization (e.g., SOP, POS, Karnaugh maps)
16E	Section 6.0	Flip-flops and counters
16F	Section 7.0	Programmable logic devices and gate arrays
16G	Section 8.0	State machine design
16H	Section 9.0	Data path/controller design
16I	Section 10.0	Timing (diagrams, asynchronous inputs, races, hazards)
	Section 11.0	Practice Exam Problems

## 2.0 NUMBER SYSTEMS

There are three number systems that you should know for this section, (1) Decimal, (2) Binary and (3) Hexadecimal. The decimal system is the system that you often use. It uses the integers 0-9 to represent.

### 2.1 CONVERT DECIMAL (INTEGERS) TO BINARY

When converting integers to binary numbers, you should create the table below and use it as a guide. The table reads from left to right and it is all the powers of 2.

$2^7$	$2^6$	$2^5$	$2^4$	$2^3$	$2^2$	$2^1$	$2^0$
128	64	32	16	8	4	2	1
X	X	X	X	X	X	X	X

When you convert an integer to binary, you must take the largest power of 2 and then add up all the values of the powers of 2, from left to right to add up to the integer. For example, “17” is created by starting with 16 and then adding up all the values required from left to right until the sum 17 is created. In this case it is just the 4<sup>th</sup> power and the 0<sup>th</sup> power. A “1” is placed underneath all the powers that apply to this integer and a zero for all those that don’t apply.

$2^7$	$2^6$	$2^5$	$2^4$	$2^3$	$2^2$	$2^1$	$2^0$
128	64	32	16	8	4	2	1
0	0	0	1	0	0	0	1

$$17 \rightarrow 10001$$

Now try it one more time by creating “30”. Start at “16” and place a “1” underneath. Then place another “1” under “the 3<sup>rd</sup> power, this gives you 24. Then another “1” under the 2<sup>nd</sup> power, which gives you 28. Finally, another “1” under the 1<sup>st</sup> power.

$2^7$	$2^6$	$2^5$	$2^4$	$2^3$	$2^2$	$2^1$	$2^0$
128	64	32	16	8	4	2	1
0	0	0	1	1	1	1	0

$$30 \rightarrow 11110$$

#### 2.1.1 Using Your Ti-36 Pro

Now that you understand how to complete this process manually, you should also know how to complete this process with your calculator. On the FE exam, any calculation you can complete quickly on your calculator will greatly help you to save time that can be used on more complicated questions.

- Step 1: Type Decimal Number, 17

- Step 2: Insert type at the end of the number, type **2<sup>nd</sup>**, **base n**, Type, d
- Step 3: Insert convert, type **2<sup>nd</sup>**, **base n**, Convert, ► Bin
- Your calculator should look like this, 17d► Bin
- Step 4: Press enter, 17d► Bin 10001b

Try the process again but this time with “30”

- Step 1: Type Decimal Number, 30
- Step 2: Insert type at the end of the number, type **2<sup>nd</sup>**, **base n**, Type, d
- Step 3: Insert convert, type **2<sup>nd</sup>**, **base n**, Convert, ► Bin
- Your calculator should look like this, 30d► Bin
- Step 4: Press enter, 30d► Bin 11110b

## 2.2 CONVERT BINARY TO DECIMAL (INTEGERS)

When converting from binary to integers, you should use the same technique just in reverse. First, create the table and fill in the binary “1s” and “0s”. Then fill out the power values that have a “1” and leave the other cells blank or place a zero in those cells.

0	0	0	1	0	1	1	0
$2^7$	$2^6$	$2^5$	$2^4$	$2^3$	$2^2$	$2^1$	$2^0$
0	0	0	16	0	4	2	0

Finally, add up all the values.

$$16 + 4 + 2 = 22$$

$$10110 \rightarrow 22$$

The next example converts, 1110110 to an integer.

0	1	1	1	0	1	1	0
$2^7$	$2^6$	$2^5$	$2^4$	$2^3$	$2^2$	$2^1$	$2^0$
0	64	32	16	0	4	2	0

Finally, add up all the values.

$$64 + 32 + 16 + 4 + 2 = 118$$

$$1110110 \rightarrow 118$$

### 2.2.1 Using Your Ti-36 Pro

Now that you understand how to complete this process manually, you should also know how to complete this process with your calculator. On the FE exam, any calculation you can complete quickly on your calculator will greatly help you to save time that can be used on more complicated questions.

- Step 1: Type Binary Number, “10110”
- Step 2: Insert type at the end of the number, type **2<sup>nd</sup>**, **base n**, Type, b
- Step 3: Insert convert, type **2<sup>nd</sup>**, **base n**, Convert, ►Dec
- Your calculator should look like this, 10110b►Dec
- Step 4: Press enter, 10110b ►Dec    22

Try the process again but this time with “1110110”

- Step 1: Type Binary Number, “1110110”
- Step 2: Insert type at the end of the number, type **2<sup>nd</sup>**, **base n**, Type, b
- Step 3: Insert convert, type **2<sup>nd</sup>**, **base n**, Convert, ►Dec
- Your calculator should look like this, 1110110b►Dec
- Step 4: Press enter, 1110110b►Dec    118

## 2.3 CONVERT DECIMAL (FRACTIONS) TO BINARY

When you convert fractions to binary, you have to follow a different method. In this method, you will convert the values to the right of the decimal point by multiplying this values by 2 and then shifting the values over to the left side of the decimal point. For example, convert 0.25 to binary.

Step	Math		Resultant	Binary
Step 1	0.25 x 2	=	0.5	0
Step 2	0.5 x 2	=	1.0	1

$$\frac{1}{4} \rightarrow 0.25 \rightarrow .01$$

Next, try this same process for a more complex fraction, like 0.2375.

Step	Math		Resultant	Binary
Step 1	0.2375 x 2	=	0.475	0
Step 2	0.475 x 2	=	0.95	0
Step 3	0.95 x 2	=	1.9	1
Step 4	0.9 x 2	=	1.8	1
Step 5	0.8 x 2	=	1.6	1
Step 6	0.6 x 2	=	1.2	1
Step 7	0.2 x 2	=	0.4	0

$$0.2375 \rightarrow .0011110$$

# Section 17.0 – Computer Systems

## Table of Contents

1.0	Introduction .....	3
2.0	Computer System Architecture .....	3
2.1	Types .....	3
2.1.1	Multiprocessing .....	3
2.2.2	Multithreading .....	4
2.2	Pipelining .....	4
2.2.1	Cycle Time .....	6
3.0	Microprocessors .....	7
3.1	Components .....	7
3.1.1	Arithmetic Logic Unit (ALU) .....	7
3.1.2	Control Unit (CU) .....	7
3.1.3	Input/Output (I/O) .....	7
3.1.4	Register .....	7
3.1.5	Cache .....	8
3.1.6	Buses .....	8
3.2	Microprocessor Architecture .....	8
3.2.1	Harvard Architecture .....	8
3.2.2	Von Neumann Architecture .....	9
3.3	Memory Addressing .....	9
3.3.1	Immediate Addressing .....	10
3.3.2	Register Addressing .....	10
3.3.3	Direct Addressing .....	11
3.3.3	Register Indirect Addressing .....	12
3.3.4	Indexed Addressing .....	12
4.0	Memory Technology and Systems .....	13
4.1	Random Access Memory (RAM) .....	14
4.2	Read Only Memory (ROM) .....	14
4.3	Cache .....	15
4.4	Placement Policy .....	15
4.4.1	Direct Mapped Cache .....	15
4.4.2	Set Associative Cache .....	18



4.4.3	Fully Associative Cache .....	19
4.4	Replacement Policy .....	19
4.4.1	Least Recently Used (LRU).....	20
4.4.2	Most Recently Used (MRU).....	22
4.4.3	First-In, First-Out (FIFO).....	22
4.4.4	Random.....	24
4.4.5	Least Frequently Used (LFU) .....	24
5.0	Interfacing .....	24
6.0	Practice Exam Problems .....	25
6.1	Practice Exam Problem 1 - Cache .....	25
6.2	Practice Exam Problem 2 - Cache .....	25
6.3	Practice Exam Problem 3 - Pipelining .....	26
6.4	Practice Exam Problem 4 - Addressing .....	26
6.5	Practice Exam Problem 5 - Addressing .....	27
6.6	Practice Exam Problem 6 - Addressing .....	27
7.0	Practice Exam Solutions .....	28
7.1	Practice Exam Solution 1 - Cache .....	28
7.2	Practice Exam Solution 2 – Cache .....	28
7.3	Practice Exam Solution 3 – Pipelining .....	29
7.4	Practice Exam Solution 4 – Addressing .....	30
7.5	Practice Exam Solution 5 – Addressing .....	30
7.6	Practice Exam Solution 6 - Addressing .....	31



## 1.0 INTRODUCTION

Computer Systems accounts for approximately 4 to 6 questions on the Electrical & Computer Engineering FE exam. These questions can cover Architecture, Microprocessors, Memory Technology and Systems and Interfacing.

The *NCEES FE Reference Handbook* Computer Systems section has very little information on computer systems. There are about two pages that briefly explain the overall concepts of architecture, microprocessors and memory systems. There is no information on interfacing.

Section 17.0 Computer Systems (4 to 6 Problems)		
NCEES Outline Value	Engineering Pro Guides	
	Section 1.0	Introduction
17A	Section 2.0	Architecture (e.g., pipelining, cache memory)
17B	Section 3.0	Microprocessors
17C	Section 4.0	Memory technology and systems
17D	Section 5.0	Interfacing
	Section 6.0	Practice Exam Problems

## 2.0 COMPUTER SYSTEM ARCHITECTURE

The architecture of a computer system defines how the components within a computer system operate with each other.

### 2.1 TYPES

There are two types of computer architecture that you should know for the exam, because these are presented in the FE Reference Handbook. These types are called multicore and multithreading. In each of these types, the purpose of the architecture is to decrease computing type and to increase the speed of the computer.

#### 2.1.1 Multiprocessing

In a multiprocessing architecture, there are multiple processes running within a single computer. Each processor has their own thread. Multiprocessing allows for multiple programs to be running at the same time. Each of the processes or programs are running concurrently. Multiprocessing does not share resources like memory, so each process requires a copy of memory.

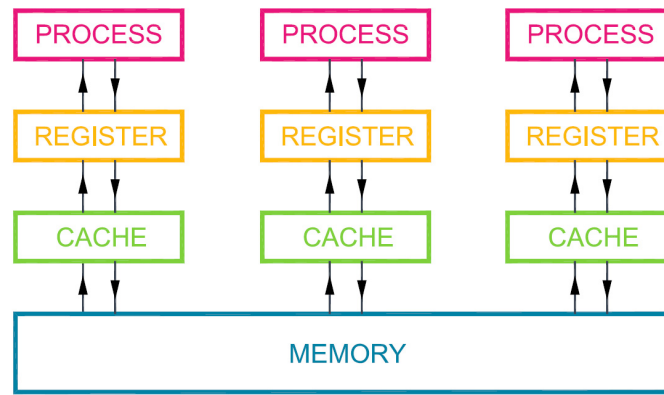

Figure 1: This figure shows multiprocessing architecture. Multiple processes are being run by the CPU. Each process creates its own cache and register. In the event data is not available at the register or cache, then the process fetches data from the register, which fetches data from the cache and finally back to the memory. If data is available at the register level, then the process does not need to access the cache or memory.

## 2.2.2 Multithreading

In a multithreading architecture, there are multiple threads for a single process. A thread is a segment of code. The threads all share the same resources from that single process, this includes memory. In a multiprocessing architecture, each process has to create copies of the memory between the various processes that may use the same data.

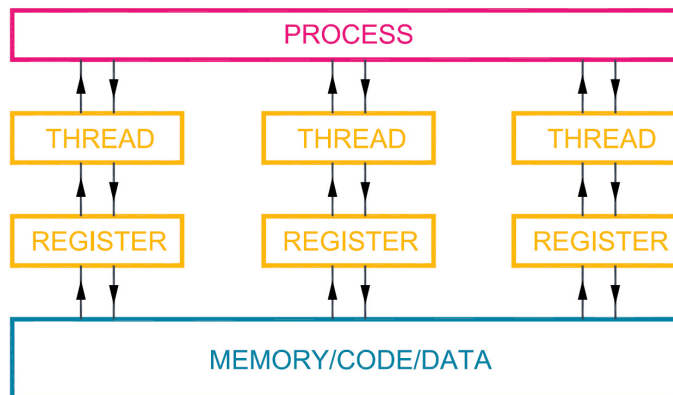

Figure 2: This figure shows multi-threading. There is only one process, but multiple threads under that process. Each thread shares the same cache and memory. However, each thread still has its own register.

## 2.2 PIPELINING

Pipelining is the act of conducting multiple instructions in parallel. This will reduce computing time, as compared to conducting instructions in series. An instruction will typically consists of the following five stages.



- Pipeline Stage 1: Instruction Fetch (IF)
  - The processor will read the instructions as shown in Memory Addressing under Microprocessors. The memory address that will be read is determined by the program counter register. The microprocessor section briefly discusses the various registers.
- Pipeline Stage 2: Instruction Decode (ID)
  - The processor will interpret or decode the instructions and the appropriate registry component will be accessed.
- Pipeline Stage 3: Instruction Execute (IE)
  - The processor will carry out the operation in the arithmetic logic unit.
- Pipeline Stage 4: Memory Access (MA)
  - The processor will access the primary memory or cache and ready or write to the memory system.
- Pipeline Stage 5: Write Back (WB)
  - The processor will write to the register.

Pipelining will execute a series of instructions as soon as the previous instruction leaves a stage. Once instruction 1 leaves stage 1, then instruction 2 will enter into stage 1.

The advantages of pipelining is the reduction in time and the increase in the amount of instructions that can be computed.

The disadvantages include the increased cost due to increased complexity. There are many possible conflicts that can occur that must be accounted for in the architecture design. An instruction may rely on data from a previous instruction or future instruction and that data may change over time. Different instructions at various levels of completeness may rely on the same data at various times, so it must be ensured that the first instruction accesses that data first, before other instructions change that data. There are many other complexities that could arise that are outside of the scope of this document and the FE exam.

Clock Cycle Time

Instruction	1	2	3	4	5	6	7	8
000000	IF	ID	IE	MA	WB			
000001						IF	ID	IE
000010								
000011								

*Figure 3: This figure shows instructions without pipelining. The top row of numbers shows the clock cycle. For example, at the 2<sup>nd</sup> clock cycle, the instruction decode task is taking place for instruction 000000. At clock cycle 6, the instruction fetch task is taking place for instruction 000001.*



# 1 8- Software Development

---

Algorithms, Data structures, Software design methods (structured, object-oriented), Software implementation (e.g., procedural, scripting languages), Software testing



# Section 18.0 – Software Development

## Table of Contents

1.0	Introduction .....	2
2.0	Algorithms .....	3
2.1	Sorting Algorithms .....	3
2.1.1	Bubble Sort.....	3
2.1.3	Merge Sort.....	6
2.1.4	Heap Sort .....	6
2.2	Searching Algorithms .....	9
2.2.1	Binary Search.....	9
2.2.2	Hashing .....	10
2.3	Algorithm Efficiency .....	11
2.3.1	Constant: $O((-1^n))$ .....	11
2.3.2	Sequential: $O(n)$ .....	11
2.3.3	Quadratic: $O(n^2)$ .....	11
2.3.4	Logarithmic: $O(\log n)$ .....	11
2.4	Tree Traversal .....	12
2.4.1	In-order Traversal.....	12
2.4.2	Pre-order Traversal .....	13
2.4.3	Post-order Traversal.....	14
2.5	Graph Traversal.....	14
2.5.1	Depth Traversal.....	15
2.5.2	Breadth Traversal.....	15
3.0	Data Structures .....	16
4.0	Software Design Methods .....	16
4.1	Waterfall .....	16
4.2	Iterative.....	16
4.3	V-Model .....	17
5.0	Software Implementation .....	17
5.1	Software Syntax .....	18
5.2	Flow Chart Definition .....	18
5.3	Unified Modified Language (UML).....	19
5.3.1	Extends .....	19



5.3.2	Implements.....	19
5.3.3	Class Relationships.....	19
6.0	Software Testing.....	20
6.1	McCabe's Cyclomatic Complexity.....	20
7.0	Practice Exam Problems.....	21
7.1	Practice Exam Problem 1 – Algorithms.....	21
7.2	Practice Exam Problem 2 – Algorithms.....	21
7.3	Practice Exam Problem 3 – Tree Traversal.....	22
7.4	Practice Exam Problem 4 – Tree Traversal.....	22
7.5	Practice Exam Problem 5 – Data Structures.....	23
7.6	Practice Exam Problem 6 – Software Testing.....	23
8.0	Practice Exam Solutions.....	24
8.1	Practice Exam Solution 1 – Algorithms.....	24
8.2	Practice Exam Solution 2 - Algorithms.....	24
8.3	Practice Exam Solution 3 – Tree Traversal.....	24
8.4	Practice Exam Solution 4 – Tree Traversal.....	25
8.5	Practice Exam Solution 5 – Data Structures.....	26
8.6	Practice Exam Solution 6 – Software Testing.....	27

## 1.0 INTRODUCTION

Software Development accounts for approximately 4 to 6 questions on the Electrical FE exam. These questions can cover a vast range of topics from algorithms, data structures, software design methods, software implementation and software testing. This information given in the NCEES FE Reference Handbook does not cover Software Development in depth. There is brief mention of the typical sub-topics within each main topic. For example, the NCEES FE Reference Handbook does mention Algorithm Tree Traversal methods but it does not give detailed information. This seems to imply that the questions on these topics will not be detailed and will mainly skim over the main concepts behind each of the subtopics mentioned in the handbook. This section will give you that knowledge, such that you can use the vague information in the handbook to answer most of the problems on this topic.

Section 18.0 Software Development (4 to 6 Problems)		
NCEES Outline Value	Engineering Pro Guides	
	Section 1.0	Introduction
18A	Section 2.0	Algorithms
18B	Section 3.0	Data structures
18C	Section 4.0	Software design methods (structured, object-oriented)
18D	Section 5.0	Software implementation (e.g., procedural, scripting languages)
18E	Section 6.0	Software testing
	Section 7.0	Practice Exam Problems

## 2.0 ALGORITHMS

An algorithm is the way a software program processes and travels through data. There are different types of algorithms that you should know for the FE Electrical exam. The first group of algorithms is the sorting algorithms that sort a collection of data into a specific order.

### 2.1 SORTING ALGORITHMS

#### 2.1.1 Bubble Sort

In a bubble sort, adjacent values are compared and the larger value is swapped to the right after each comparison. This will cause the largest value to bubble up at the end of the array. This process is then repeated iteratively, until the entire array has been sorted. This sorting algorithm will be explained further with this example array. Each subsequent algorithm will also use this same array.

Sample Array  $\rightarrow \{8, 4, 9, 1, 2\}$

8	4	9	1	2
4	8	9	1	2
4	8	9	1	2
4	8	1	9	2
4	8	1	2	9

Figure 1: In the first iteration, the first two values of the array are compared. The larger value is moved to the right. This is shown in red in the first row. In the second row, the “8” has switched to the right and now the next two values, “8” and “9” are being compared. The larger value goes to the right. In the third row, the “9” and “1” are being compared and in the fourth row the “9”

has moved to the right. Finally the “9” and “2” are compared and the “9” moves to the right most.

4	8	1	2	9
4	8	1	2	9
4	1	8	2	9
4	1	2	8	9

Figure 2: In the second iteration, the process is repeated from left to right. You should be able to see how the “8” is bubbling up to the right.

4	1	2	8	9	1	2	4	8	9
1	4	2	8	9	1	2	4	8	9
1	2	4	8	9					

Figure 3: The third iteration is shown on the left and the fourth iteration is shown on the right. The “4” bubbles to the right in the third iteration and in the fourth iteration, the “2” is already in the correct spot.

Bubble Sort  $\rightarrow O(n^2)$

### 2.1.2 Insertion Sort

The insertion sort algorithm starts from the left of an array and moves to the right. It will take the value and compare it to the value on the left. If the value is less than the value to the left, then it will swap places. If the value is greater than the value to the left, then it will assume it is sorted and move on.

8	4	9	1	2
---	---	---	---	---

Figure 4: The first step is to compare “8” to nothing on the left, so it is considered sorted and you move on to the next spot.

8	4	9	1	2
4	8	9	1	2

Figure 5: Next, you compare the "4" value to the value to the left which is "8". Since the value is less, than you swap places. You then check the "8" and then your first two spots are considered sorted.

4	8	9	1	2
---	---	---	---	---

Figure 6: The next spot has a "9", so these three spots are considered sorted, because the "9" is greater than the "8".

4	8	9	1	2
4	8	1	9	2
4	1	8	9	2
1	4	8	9	2

Figure 7: The next spot has a "1". The "1" is compared with the "9", then swaps places and so on and so on, until the "1" is at the beginning of the array.

1	4	8	9	2
1	4	8	2	9
1	4	2	8	9
1	2	4	8	9

Figure 8: The same process is completed for the "2" value in the final iteration.

Insertion Sort  $\rightarrow O(n^2)$

### 2.1.3 Merge Sort

The merge sort algorithm will split up each value of the array and will sort as values are merged into subsequently larger arrays. First, each value is created into its own array. Then the first two values are sorted between each other into a new two value array. The third and fourth values are sorted into their own array. In this subsequent example, there is an odd amount, so the last value is simply put into its own array.

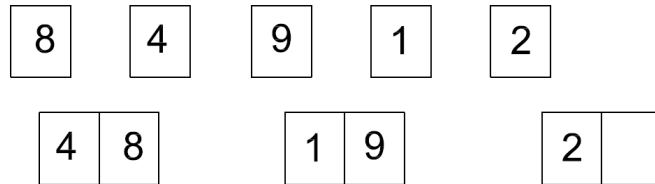

Figure 9: Single values are sorted into new two-value arrays.

Next, the adjacent 2-value arrays are merged and sorted into a 4-value array.

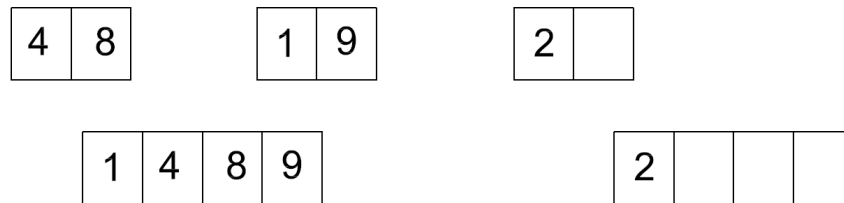

Figure 10: The first and second values of the adjacent arrays are compared and the smallest value is placed into the new 4-value array. The remaining value is then compared against the next value in the adjacent array, so the “4” is compared to the “9”, and then the “4” is placed into the array. The “8” is then compared to the “9” and then the “8” is placed into the array.

Next, the adjacent 4-value arrays are compared and sorted into one large array.

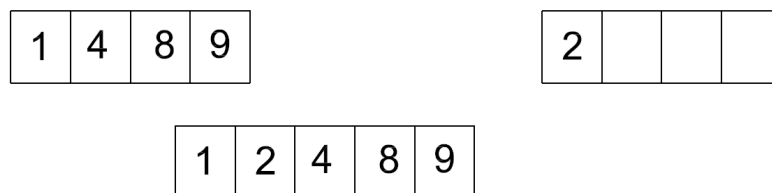

Figure 11: The “1” and “2” are compared, the “1” is smaller so it is placed into the array first. The “2” is then compared to the “4” and the “2” is smaller so then it is placed into the array. Finally the remaining values are placed into the array in order.

Merge Sort  $\rightarrow O(n \log n)$

### 2.1.4 Heap Sort

This sorting method creates a binary tree and places each data point in order. A binary tree starts at the root and then branches out. Each node will have a maximum of two branches.





## 7.0 PRACTICE EXAM PROBLEMS

### 7.1 PRACTICE EXAM PROBLEM 1 – ALGORITHMS

What is the Big O representation for binary search?

- (a)  $O(n)$
- (b)  $O(n \log n)$
- (c)  $O(n^2)$
- (d)  $O(\log n)$

### 7.2 PRACTICE EXAM PROBLEM 2 – ALGORITHMS

Which of the following sort algorithms has the best Big O efficiency?

- (a) Bubble sort
- (b) Insertion sort
- (c) Merge sort
- (d) Quick sort

### 7.3 PRACTICE EXAM PROBLEM 3 – TREE TRAVERSAL

The following tree is traversed post-order. Which of the following is the correct output of the post-order traversal?

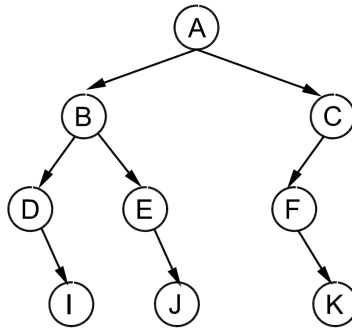

- (a) I – D – J – E – B – K – F – C – A
- (b) A – B – C – D – E – F – I – J – K
- (c) I – J – K – D – E – F – B – C – A
- (d) B – D – I – E – J – C – F – K – A

### 7.4 PRACTICE EXAM PROBLEM 4 – TREE TRAVERSAL

The following tree is traversed in-order. Which of the following is the correct output of the in-order traversal?

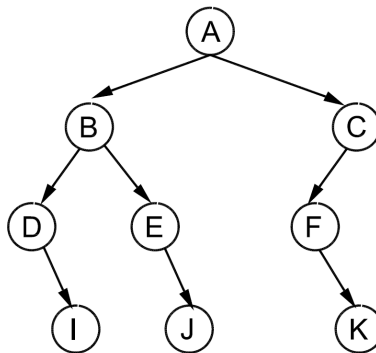

- (a) I – D – J – E – B – K – F – C – A
- (b) A – B – C – D – E – F – I – J – K
- (c) I – D – B – E – J – A – C – F – K
- (d) B – D – I – E – J – C – F – K – A

## 7.5 PRACTICE EXAM PROBLEM 5 – DATA STRUCTURES

Which of the following options is an advantage to data structures?

- (a) Isolated data
- (b) Redundant data
- (c) Data security
- (d) Organized data

## 7.6 PRACTICE EXAM PROBLEM 6 – SOFTWARE TESTING

What is the complexity of the below software program?

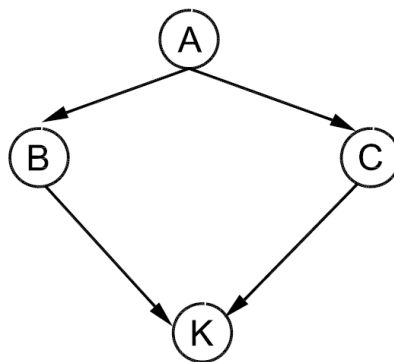

- (a) 1
- (b) 2
- (c) 3
- (d) 4

## 8.0 PRACTICE EXAM SOLUTIONS

### 8.1 PRACTICE EXAM SOLUTION 1 – ALGORITHMS

What is the Big O representation for binary search?

**The correct answer is most nearly, (a)  $O(n)$ .**

- (a)  $O(n)$
- (b)  $O(n \log n)$
- (c)  $O(n^2)$
- (d)  $O(\log n)$

### 8.2 PRACTICE EXAM SOLUTION 2 - ALGORITHMS

Which of the following sort algorithms has the best Big O efficiency?

**The correct answer is most nearly, (c) Merge sort.**

- (a) Bubble sort
- (b) Insertion sort
- (c) Merge sort
- (d) Quick sort

### 8.3 PRACTICE EXAM SOLUTION 3 – TREE TRAVERSAL

The following tree is traversed post-order. Which of the following is the correct output of the post-order traversal?

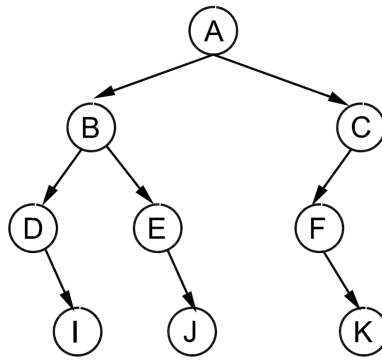

In order to complete this problem, draw the post-order traversal lines. Then number the nodes, when each right-hand side of the node is touched.

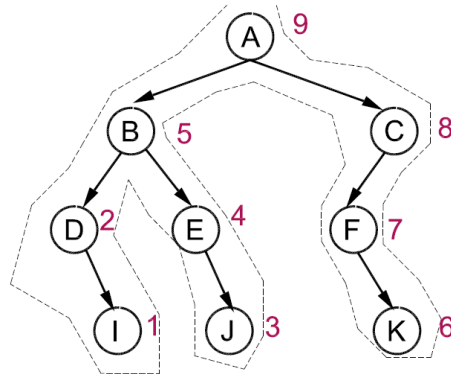

The correct answer is most nearly, (a) I – D – J – E – B – K – F – C – A.

- (a) I – D – J – E – B – K – F – C – A
- (b) A – B – C – D – E – F – I – J – K
- (c) I – J – K – D – E – F – B – C – A
- (d) B – D – I – E – J – C – F – K – A

#### 8.4 PRACTICE EXAM SOLUTION 4 – TREE TRAVERSAL

The following tree is traversed in-order. Which of the following is the correct output of the in-order traversal?

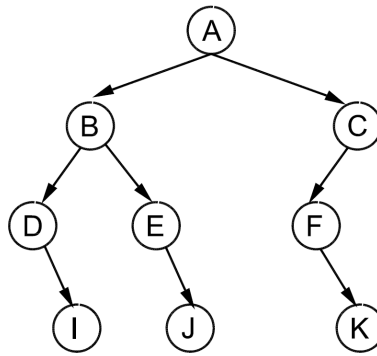

In order to complete this problem, draw the in-order traversal lines. Then number the nodes, when each bottom side of the node is touched. But remember you have to start with the bottom of the left-most branch.

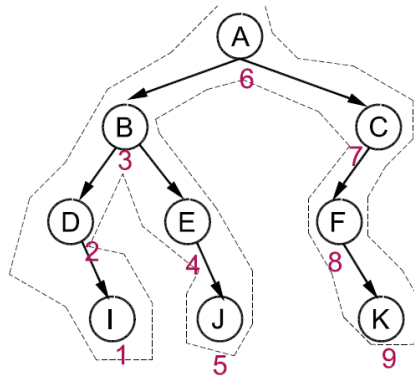

The correct answer is most nearly, (c) I – D – B – E – J – A – C – F – K.

## 8.5 PRACTICE EXAM SOLUTION 5 – DATA STRUCTURES

Which of the following options is an advantage to data structures?

- (a) Isolated data
- (b) Redundant data
- (c) Data security
- (d) Organized data

Data structures will integrate data, so (a) isolated data is incorrect.

Data structures will also eliminate the need for redundant data. Redundant data uses excess space and increases computing time. (b) Redundant data is incorrect.

Data security is not a function of data structures.

Data structures will integrate and organize data, so that data can use space efficiently and retrieval time is minimized.

**The correct answer is most nearly, (d) organized data.**

## 8.6 PRACTICE EXAM SOLUTION 6 – SOFTWARE TESTING

What is the complexity of the below software program?

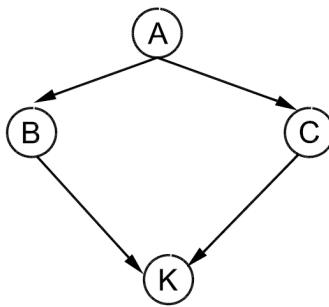

$$c = 4 - 4 + 2 = 2$$

**The correct answer is most nearly, (b) 2.**

- (a) 1
- (b) 2
- (c) 3
- (d) 4



# 19 – Full Exam

---

Full length Electrical & Computer FE Exam (110 problems)



To simulate the actual exam, set aside 5 hours and 45 minutes. The exam is broken up into 2 sessions with a 25 minute break in between. Only use the *NCEES FE Reference Handbook* as a resource during the exam. Recommend that you use the latest pdf version of the handbook with the “search” function to better simulate the actual exam.

**SESSION 1:** Set your countdown timer to 5 hours and 20 minutes. Complete the first session and pause the timer when done. Be aware of your time, you should have about half the amount of time left for Session 2.

**BREAK:** Allot yourself a maximum 25 minute break. You may take less than a 25 minutes.

**SESSION 2:** Resume the countdown timer and complete the rest of the exam with the remaining time. Do not go back to Session 1, you will not be able to review any of the Session 1 problems after it is submitted during the real test.



## 1.0 FULL EXAM PROBLEMS

Total time for the 110 questions is 5 hours and 20 minutes.

-- START SESSION 1 --

### 1.1 PROBLEM 1 – MATHEMATICS

Convert the following value to polar form.

$$5 + \sqrt{-49}$$

- (a)  $8.6 \angle 55^\circ$
- (b)  $5 + 7 \angle 50^\circ$
- (c)  $8.6 \angle -55^\circ$
- (d)  $5 \angle -55^\circ$

### 1.2 PROBLEM 2 – MATHEMATICS

Find the product of the following two vectors, a & b.

$$a = 5 + 6i; \quad b = \sqrt{2} - 7i;$$

- (a)  $56 \angle 28^\circ$
- (b)  $49 \angle 14^\circ$
- (c)  $56 \angle -28^\circ$
- (d)  $49 \angle -14^\circ$

### 1.3 PROBLEM 3 – MATHEMATICS

Find the product of the following two vectors, a & b.

$$a = 5 + 6i; \quad b = \sqrt{2} - 7i;$$

- (a)  $7 - 42i$
- (b)  $56\angle 28^\circ$
- (c)  $7 + 42i$
- (d)  $49 - 26.5i$

### 1.4 PROBLEM 4 - MATHEMATICS

Which of the following is not a solution to the below equation?

$$x^5 + 32 = 0$$

- (a)  $-0.62 + 1.9i$
- (b)  $-2$
- (c)  $0.62 + 1.9i$
- (d)  $1.9 + 0.62i$



## 1.5 PROBLEM 5 – MATHEMATICS

The following a-b-c triangle has sides and an angle shown below. What is the length of the remaining side?

$$a = 20; B = 75^\circ; c = 30;$$

- (a) 23
- (b) 27
- (c) 31
- (d) 990

## 1.6 PROBLEM 6 - MATHEMATICS

Find the inflection point of the following equation.

$$y = e^x - 5x^2$$

- (a) (2.3, -16.5)
- (b) (-2.3, -16.5)
- (c) (16, 2)
- (d) (2.3, 0)

## 1.7 PROBLEM 7 – MATHEMATICS

Find the partial derivative of the following function.

$$f(x, y) = 4 \sin(3x - 7y)$$

$$\frac{\partial^2 f}{\partial x^2} = ?$$

- (a)  $4 \cos(3x - 7y)$
- (b)  $-12 \cos(3x - 7y)$
- (c)  $12 \sin(3x - 7y)$
- (d)  $-36 \sin(3x - 7y)$

## 1.8 PROBLEM 8 - MATHEMATICS

Find the equation of the plane that is parallel to the below plane and travels through the point (-2, 2, 2).

$$10 = 10i - 2j + 2k$$

- (a)  $5i + 2j + 2k = 10$
- (b)  $10i - 2j - 2k = 20$
- (c)  $5i + j + k = 5$
- (d)  $-5i + j - k = 20$

## 1.9 PROBLEM 9 – MATHEMATICS

Find the equation for the function,  $y$ .

$$y'' + 20y' = 0$$

$$y(0) = 5; y'(0) = 2$$

(a)  $4.9 + 0.1e^{10x}$

(b)  $5.1 - 0.1e^{-20x}$

(c)  $5.1 + 0.1e^{20x}$

(d)  $5.0 + 0.1e^{-2x}$

## 1.10 PROBLEM 10 - MATHEMATICS

Solve for the matrix,  $B$ .

$$A \times B = C$$

$$A = \begin{bmatrix} 2 & 4 \\ -1 & 5 \end{bmatrix}; C = \begin{bmatrix} 6 & -2 \\ 6 & 7 \end{bmatrix}$$

(a)  $\begin{bmatrix} 0.43 & -2.71 \\ 1.29 & 0.86 \end{bmatrix}$

(b)  $\begin{bmatrix} -1 & 4.11 \\ 0.67 & 0.98 \end{bmatrix}$

(c)  $\begin{bmatrix} 8 & 2 \\ -8 & 4 \end{bmatrix}$

(d)  $\begin{bmatrix} 36 & 24 \\ 24 & 37 \end{bmatrix}$

### 1.11 PROBLEM 11 – MATHEMATICS

Given the following function, solve for the following point.

$$f(x, y) = -5x^2 + y^2 - 7xy$$

$$f_x(1,1) = ?$$

- (a) -10
- (b) -3
- (c) 7
- (d) 10

### 1.12 PROBLEM 12 - MATHEMATICS

Find the derivative of the following function.

$$y = 4^{2x}$$

- (a)  $0.6 * 4^x$
- (b)  $1.3 * 4^x$
- (c)  $2.8 * 4^x$
- (d)  $2.8 * 4^{2x}$



### 1.13 PROBLEM 13 – PROBABILITY & STATISTICS

A manufacturing process is shown to produce satisfactory products at an 80% satisfactory rate. What is the probability that only 7 out of 10 products will be satisfactory?

- (a) 12%
- (b) 20%
- (c) 32%
- (d) 70%

### 1.14 PROBLEM 14 - PROBABILITY & STATISTICS

A population has a mean of 25 and a standard deviation of 5. The population is assumed to follow a normal distribution. What is the probability that a sample will be greater than 34?

- (a) 3.6%
- (b) 8.1%
- (c) 13.2%
- (d) 96%

### 1.15 PROBLEM 15 - PROBABILITY & STATISTICS

What is the t-value for the following scenario? A sample group of 10 widgets is selected. The sample group has a mean of 110 and a standard deviation of 8. The population mean is estimated as 100.

- (a) 0.09
- (b) 0.31
- (c) 0.40
- (d) 1.43

### 1.16 PROBLEM 16 - PROBABILITY & STATISTICS

A fair, 6-sided die is rolled 9 times. What is the probability that a 4 is rolled only once?

- (a) 0.15
- (b) 0.35
- (c) 0.66
- (d) 0.81

### 1.17 PROBLEM 17 - PROBABILITY & STATISTICS

A fair, 6-sided die is rolled 8 times. What is the probability that an even number is rolled less than 4 times?

- (a) 0.03
- (b) 0.10
- (c) 0.22
- (d) 0.36



-- END SESSION 1 --



### 1.56 PROBLEM 56 - SIGNAL PROCESSING

What is the inverse Z-transform of the following function?

$$\frac{1}{(z)(z - 1)}$$

- (a)  $u^*[k-2]$
- (b) 1
- (c)  $2^*u[k]$
- (d)  $u[k+2]$

### 1.57 PROBLEM 57 - SIGNAL PROCESSING

What is the inverse Z-transform of the following function?

$$\frac{1}{(z + 3)(z - 1)}$$

- (a)  $u[k - 1] * (-0.08333)$
- (b)  $u[k] * (-0.08333(-1)^k + 0.25)$
- (c)  $u[k] * (0.25)$
- (d)  $u[k - 1] * (-0.08333(-1)^{k-1} + 0.25)$

### 1.58 PROBLEM 58 - SIGNAL PROCESSING

What is the cut-off frequency of the following filter?

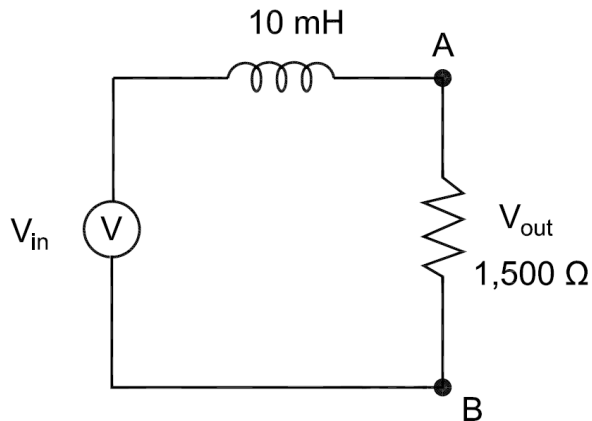

- (a) 16,000 Hz
- (b) 50,000 Hz
- (c) 150,000 Hz
- (d) 24,000 Hz

### 1.59 PROBLEM 59 - SIGNAL PROCESSING

Which of the following is most nearly true about signal filters?

- (a) Inductors let through high frequencies and Capacitors block low frequencies.
- (b) Inductors let through low frequencies and Capacitors block low frequencies.
- (c) Inductors let through high frequencies and Capacitors block high frequencies.
- (d) Inductors let through low frequencies and Capacitors block high frequencies.

### 1.60 PROBLEM 60 – ELECTRONICS

Find the conductivity of the following semi-conductor.

Si is doped with Ga. The dopant concentration is  $5 \times 10^{15} \text{ m}^{-3}$ .

The electron mobility is  $1 \text{ m}^2/\text{V}\cdot\text{s}$ . The hole mobility is  $0.5 \text{ m}^2/\text{V}\cdot\text{s}$ .

- (a)  $0.00002 (\Omega\cdot\text{m})^{-1}$
- (b)  $0.0001 (\Omega\cdot\text{m})^{-1}$
- (c)  $0.0004 (\Omega\cdot\text{m})^{-1}$
- (d)  $0.0010 (\Omega\cdot\text{m})^{-1}$

### 1.61 PROBLEM 61 – ELECTRONICS

What is the collector voltage ( $V_{CB}$ ) in the figure below?

$$R_1 = 22 \text{ k}\Omega ; R_2 = 75 \Omega ; V_{BE} = 0.7 \text{ V} ; \beta = 200$$

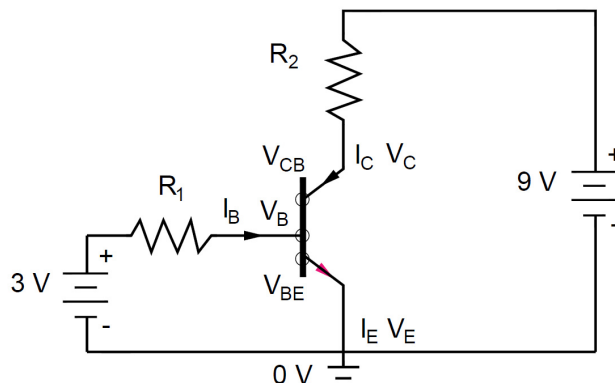

- (a) 0.7 V
- (b) 4.1 V
- (c) 6.7 V
- (d) 8.0 V

$$\overline{AC} + AB\overline{CD} + ACD$$

The correct answer is most nearly, (c).

(a)  $\overline{AC} + AD + AB\overline{CD} + ACD + ABCD$

(b)  $\overline{ABCD} + \overline{ABCD} + \overline{ABC\overline{D}} + \overline{AB\overline{CD}} + ACD$

(c)  $\overline{AC} + AB\overline{CD} + ACD$

(d)  $\overline{AB} + AB\overline{CD} + CD$

### 2.103 SOLUTION 103– COMPUTER SYSTEMS

A four-way set-associative cache has the following properties. How many words per block?

512 words & 16 cache sets.

Words are also a sequence of bits and are typically on the order of  $2^{16}$  to  $2^{64}$  bits. The size of a word must be defined for each computer system. But for this problem you just need to know that words are used as the unit as opposed to bits.

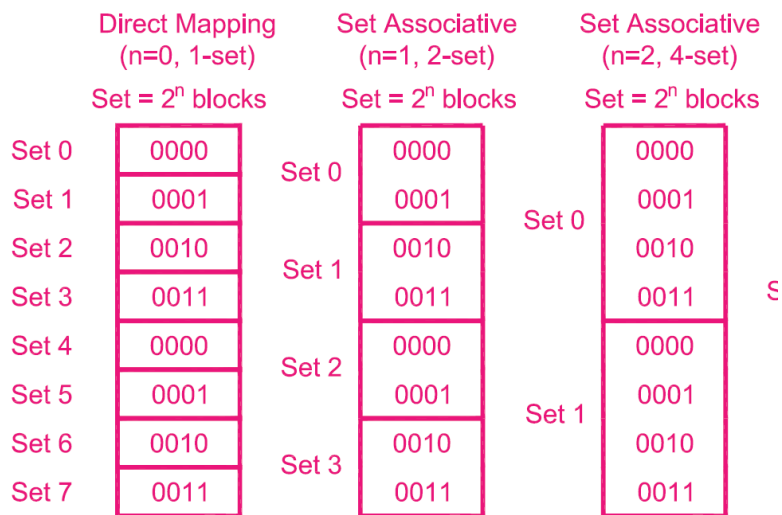

There are 16 cache sets. Each set has four lines (4-way). This means there are 64 lines or blocks. Now you can take the number of words and divide by the number of blocks.

$$\frac{512}{64} = 8 \text{ words per block}$$

The correct answer is most nearly, (d) 8.

(a) 1

(b) 2



- (c) 4
- (d) 8

## 2.104 SOLUTION 104– COMPUTER SYSTEMS

A 4 KB primary memory system has a cache of 256 bytes. The cache is direct mapped. Find the Tag bits. Block size is 2 bits.

Tag bits	Index bits	Offset bits

*Primary Memory Data Size = 4,096 bits; Cache Size = 256 bits; Block Size = 2 bits*

$$\text{Primary Memory Data (m) \# of Digits} = 4,096 = 2^m \rightarrow m = 12$$

$$\text{Block \# of Digits} = 2 = 2^b \rightarrow b = 1$$

First, you can find the offset with the block # of digits.

$$\text{Cache Offset \# of Digits} = 2 = 2^b \rightarrow b = 1$$

The index bits can be found with the size of the cache lines. Take the cache size and divide by the block size. The index would change if the cache was not direct mapped and was set associative.

$$\text{Index \# of Digits} = \frac{\text{Cache size } 256}{\text{Block size } 2} = 128 = 2^i \rightarrow i = 7$$

The tag digits is taken by subtracting the index and offset digits from the primary memory size.

$$\text{Tag Digits} = m - s - b = 12 - 7 - 1 = 4$$

Tag bits	Index bits	Offset bits
4	7	1

**The correct answer is most nearly, (a) 4.**

- (a) 4
- (b) 7
- (c) 1
- (d) 12

## 2.105 SOLUTION 105– COMPUTER SYSTEMS

A 4 KB primary memory system has a cache of 256 bytes. Block size is 2 bits. What is the difference in tag bits for a 2-way set associative cache vs. a fully associative cache?

Tag bits	Index bits	Offset bits

*Primary Memory Data Size = 4,096 bits; Cache Size = 256 bits; Block Size = 2 bits*

$$\text{Primary Memory Data (m) \# of Digits} = 4,096 = 2^m \rightarrow m = 12$$

$$\text{Block \# of Digits} = 2 = 2^b \rightarrow b = 1$$

First, you can find the offset with the block # of digits.

$$\text{Cache Offset \# of Digits} = 2 = 2^b \rightarrow b = 1$$

The index bits can be found with the 2-way set associative

$$\text{Index \# of Digits} = \text{Number of lines} = \frac{\text{Cache size 256}}{(\text{set associativity}) * (\text{block size})} = \frac{2^8}{2 * 2} \rightarrow s = 6$$

The tag digits is taken by subtracting the index and offset digits from the primary memory size.

$$\text{Tag Digits} = m - s - b = 12 - 6 - 1 = 5$$

Tag bits	Index bits	Offset bits
5	6	1

If the cache is full associative then the index bits is equal to 0. So the tag bits is equal to 11.

Tag bits	Index bits	Offset bits
11	0	1

The difference between full associative and 2-way associative is found below.

$$\text{Difference} = 11 - 5 = 6$$

**The correct answer is most nearly, (c) 6.**

- (a) 2
- (b) 4
- (c) 6
- (d) 8

## 2.106 SOLUTION 106– COMPUTER SYSTEMS

What addressing best describes the below command?

MOV AX, [0100]

This command moves [0100] to register AX. The register contents are replaced. The brackets however indicate that the data is actually found at the address [0100] in the memory. So the register is getting data directly from the memory.

**The correct answer is most nearly, (b) Direct memory addressing.**

- (a) Immediate addressing
- (b) Direct memory addressing
- (c) In-direct memory addressing
- (d) Register addressing

## 2.107 SOLUTION 107– SOFTWARE DEVELOPMENT

After completing a balanced binary search tree, determine the pre-order search traversal for the following data set. {36, 75, 12, 5, 18, 21}.

Put higher numbers to the right, lower numbers to the left

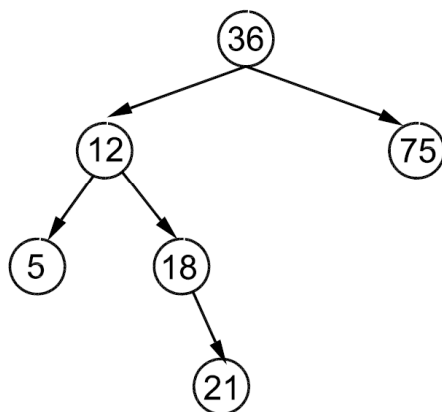

Left: Unbalanced

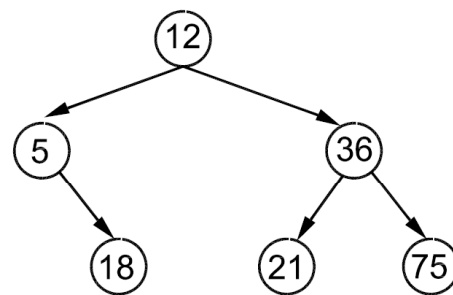

Right: Balanced

The pre-order traversal will start from the top and surround the outside of the tree. Make sure to move left.



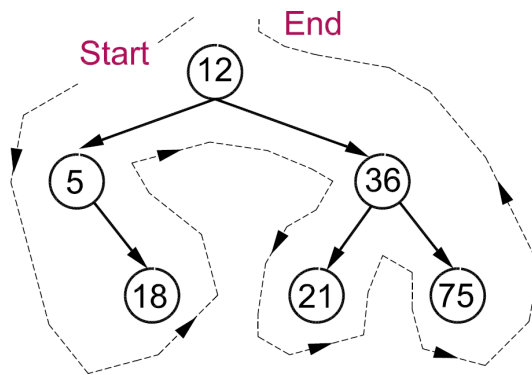

The correct answer is most nearly, (a) {12, 5, 18, 36, 21, 75}.

- (a) {12, 5, 18, 36, 21, 75}
- (b) {36, 75, 12, 5, 18, 21}
- (c) {36, 12, 5, 18, 21, 75}
- (d) {75, 36, 21, 18, 12, 5}

## 2.108 SOLUTION 108– SOFTWARE DEVELOPMENT

What is the McCabe complexity of the below diagram?

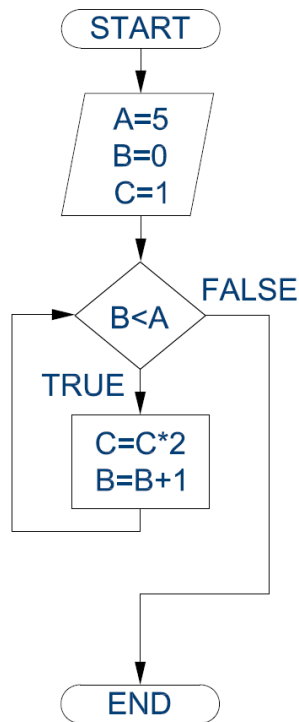

The complexity is equal to the number of decisions that need to be made plus 1. There is only 1 decision. So the complexity is equal to 2.

**The correct answer is most nearly, (c) 2.**

- (a) 0
- (b) 1
- (c) 2
- (d) 3

## 2.109 SOLUTION 109– SOFTWARE DEVELOPMENT

Which of the following is most true for merge sorts?

- (a) This method searches for the smallest entry in an array and moves it to the left.
  - (b) This method organizes the data set into a binary tree.
  - (c) This method compares adjacent entries in a single array.
  - (d) This method divides the array into halves and then combines and sorts the arrays.
- 
- (a) *This option describes selection sort.*
  - (b) *This option describes heap sort.*
  - (c) *This option describes bubble sort.*
  - (d) *This option describes merge sort.*

**The correct answer is most nearly, (d) This method divides the array into halves and then combines and sorts the arrays. ,**

## 2.110 SOLUTION 110– SOFTWARE DEVELOPMENT

Use bubble sort to sort the following array. What will be the order after one step into the sort?

{3, 2, 1, 4}

First, compare 3 and 2.  $3 > 2$ , so exchange 2 & 3.



{2, 3, 1, 4}

Second, compare 3 and 1.  $3 > 1$ , so exchange 1 & 3.

{2, 1, 3, 4}

Third, compare 3 and 4.  $3 < 4$ , so no exchange.

{2, 1, 3, 4}

Fourth, compare 2 and 1.  $2 > 1$ , so exchange 2 & 1.

{1, 2, 3, 4}

Fifth, compare 2 and 3.  $2 < 3$ , so no exchange.

{1, 2, 3, 4}

Sixth, compare 1 and 1.  $1 < 2$ , so no exchange.

**The correct answer is most nearly, (a) {2, 3, 1, 4}**

(a) {2, 3, 1, 4}

(b) {1, 2, 3, 4}

(c) {4, 3, 2, 1}

(d) {4, 3, 1, 2}

