

HVAC & Refrigeration PE Exam Technical Study Guide Errata

This product has been updated to incorporate all changes shown in the comments on the webpage and email comments as of July, 1 2020. If you have purchased this product prior to this date and wish for the latest version then please email Justin Kauwale at contact@engproguides.com.

The following changes have not been incorporated into the product as of the date above and should be noted.

$$R_{outer,convective} = \frac{1}{5} = 0.20 \left(\frac{h - ft^2 - ^\circ F}{Btu} \right)$$

For the conductivity through the pipe, you need the equivalent thickness of a pipe.

$$t_{equiv} = r_2 \ln \left(\frac{r_2}{r_1} \right) = \left(\frac{4.2 \text{ in}}{2} \right) \ln \left(\frac{\frac{4.2 \text{ in}}{2}}{\frac{4 \text{ in}}{2}} \right) = 0.1025 \text{ in} = 0.00853 \text{ ft}$$

$$R_{pipe,conductive} = \frac{0.00853 \text{ ft}}{10 \frac{Btu}{h - ft - ^\circ F}} = 0.000853 \frac{h - ft^2 - ^\circ F}{Btu}$$

For the conductivity of the insulation, you need the equivalent thickness of the insulation.

$$t_{equiv} = r_2 \ln \left(\frac{r_2}{r_1} \right) = \left(\frac{8.2 \text{ in}}{2} \right) \ln \left(\frac{\frac{8.2 \text{ in}}{2}}{\frac{4.2 \text{ in}}{2}} \right) = 2.743 \text{ in} = 0.2286 \text{ ft}$$

$$R_{insulation,conductive} = \frac{0.2286 \text{ ft}}{0.05 \frac{Btu}{h - ft - ^\circ F}} = 4.572 \frac{h - ft^2 - ^\circ F}{Btu}$$

Next, add up all the resistances, since all the materials are in series. You need to be sure to multiply the resistance by the inverse of the applicable area.

$$Inner \text{ Area} = 2\pi r_{inner}L = 2\pi * (2 \text{ in}) \left(\frac{1}{12} \right) (1 \text{ ft}) = 1.0472 \text{ ft}^2$$

$$Outer \text{ Area} = 2\pi r_{outer}L = 2\pi * (2.1 \text{ in}) \left(\frac{1}{12} \right) (1 \text{ ft}) = 1.0996 \text{ ft}^2$$

$$Insulation \text{ Outer Area} = 2\pi r_{outer,insulation}L = 2\pi * (4.1 \text{ in}) \left(\frac{1}{12} \right) (1 \text{ ft}) = 2.1468 \text{ ft}^2$$

$$\begin{aligned} R_{equivalent} &= \left(0.029 \frac{h - ft^2 - ^\circ F}{Btu} \right) \left(\frac{1}{1.0472 \text{ ft}^2} \right) + \left(0.2 \frac{h - ft^2 - ^\circ F}{Btu} \right) \left(\frac{1}{2.1468 \text{ ft}^2} \right) \\ &+ \left(0.000853 \frac{h - ft^2 - ^\circ F}{Btu} \right) \left(\frac{1}{1.0996 \text{ ft}^2} \right) + \left(4.572 \frac{h - ft^2 - ^\circ F}{Btu} \right) \left(\frac{1}{2.1468 \text{ ft}^2} \right) \\ &= 2.25 \frac{h - ^\circ F}{Btu} \end{aligned}$$

$$U_{equivalent} = \frac{1}{R_{equivalent}} = 0.44 \frac{Btu}{h - ^\circ F}$$

Finally, multiply by the driving force, which is the difference in temperature.

$$Q = 0.44 \frac{\text{Btu}}{\text{h} \cdot ^\circ\text{F}} * (300 - 75) = 100 \frac{\text{Btu}}{\text{h}} \text{ per linear foot}$$

The correct answer is most nearly, (a) 105 Btu/hr.

- (a) 105 Btu/hr
- (b) 671 Btu/hr
- (c) 1,743 Btu/hr
- (d) 2,990 Btu/hr



The total heat load from the motor can be found from the below equation:

$$\text{Total Heat} \Rightarrow Q = 2545 \frac{\text{Btuh}}{\text{HP}} * \frac{P (\text{HP})}{\text{Efficiency}}$$

$$\text{Total Heat} \Rightarrow Q = 2545 \frac{\text{Btuh}}{\text{HP}} * \frac{10 \text{ hp}}{0.8} = 31,812.50 \text{ BTUH}$$

Since the motor is located outside of the space and equipment is located in the space, then only the equipment heat loss will need to be included.

$$\text{Motor Heat Loss} \Rightarrow \text{Total Heat} * (1 - \text{Efficiency})$$

$$\text{Equipment Heat Loss} \Rightarrow \text{Total Heat} * (\text{Efficiency})$$

$$Q = 31,812.50 * (0.8) = 25,450 \text{ BTUH}$$

~~However, of this heat, only 40% is lost to the space and 60% is transferred to the air.~~

$$~~Q = 25,450 * (1 - 0.6)~~$$

$$~~Q = 10,180 \frac{\text{Btu}}{\text{hr}}~~$$

The correct answer is most nearly, (B).

4.5 SOLUTION 5 - CALCULATING HEAT LOAD FROM WINDOWS

An existing clear glass window with an inefficient film and a shading coefficient of 0.9 is being replaced by a new low-e glass with a shading coefficient of 0.6 and a transmissivity of 0.75. What will be the percent reduction in heat load by switching to the newer glass, assume an area of 18 square feet and a SCL of 40 F.

The equation governing solar heat gain from windows is as follows:

$$Q = A * SC * SCL$$

$$Q_{old} = A * 0.9 * SCL$$

$$Q_{new} = A * 0.6 * SCL$$

$$\% \text{ Reduction} = \frac{Q_{new} - Q_{old}}{Q_{old}} * 100$$

$$\% \text{ Reduction} = \frac{0.9 - 0.6}{0.9} * 100 = 33\%$$

4.7 PROBLEM 7 – COOLING LOAD CALCULATIONS

Which of the following cooling load calculation methods is most likely not a simplified method?

- (A) TETD/TA
- (B) Radiant time series
- (C) Heat balance
- (D) CLTD/CLF

4.8 PROBLEM 8 – COOLING LOAD CALCULATION

The input power to a motor is 10 HP and the motor is used to power a fan that provides 10,000 CFM. The fan has an efficiency of 67% and the motor has an efficiency of 95%. Assume the motor is running at full load (incoming 10 BHP electrical power to motor) and the motor and fan are located in the air stream. What is the amount of heat added to the air flow?

- (A) 3,100 Btu/h
- (B) 7,900 Btu/h
- (C) 9,300 Btu/h
- (D) 10,800 Btu/h

15.0 SOLUTIONS

15.1 SOLUTION 1 – FANS

Background: Two fans are placed in parallel. Each fan has the following performance, 2,000 CFM at 1.5 in. wg. If the fans are combined into a single 26" X 12" duct, then what is the resulting pressure at the end of an equivalent length of duct of 100'?

Assume standard conditions, density = 0.075 lbm/ft³ and roughness factor of 0.0007 ft.

Kinematic Viscosity of Air → $1.5 \times 10^{-4} \frac{ft^2}{s}$

First calculate the equivalent diameter of the duct:

$$D_e = \frac{1.30 * (a * b)^{0.625}}{(a + b)^{0.250}}$$
$$D_e = \frac{1.30 * (12" * 26")^{0.625}}{(12" + 26")^{0.250}}$$
$$D_e = 19" = 1.5833 ft$$

Next recognize that the fans are in parallel, thus the resulting flow rate is 4,000 CFM. Also the pressure at the outlet of the fan is assumed to be 1.5 in. wg.

On the PE exam, you will not have access to ASHRAE Fundamentals, so the other way to complete this problem is to use the equation from the NCEES Mechanical PE Reference Handbook.

$$Pressure Loss = \frac{12f}{D_e} L(\rho) \left(\frac{v}{1097} \right)^2$$

First, you need to find the friction factor from the Moody Diagram.

$$Velocity = 4,000 \frac{ft^3}{min} \div \left(\frac{\pi D_e^2}{4} \right) = 4,000 \frac{ft^3}{min} \div \left(\frac{\pi 1.5833^2}{4} \right) = 2,032 \frac{ft}{min} = 33.88 \frac{ft}{s}$$

$$Kinematic Viscosity = 1.5 \times 10^{-4} \frac{ft^2}{s}$$

$$Re = \frac{33.88 \frac{ft}{s} \times 1.5833}{1.5 \times 10^{-4} \frac{ft^2}{s}} = 357,565$$

$$Relative Roughness = \frac{\epsilon}{D} = \frac{0.0007 ft}{19"/12} = 0.00044$$

From the Moody Diagram, you will see that the friction factor is equal to .018



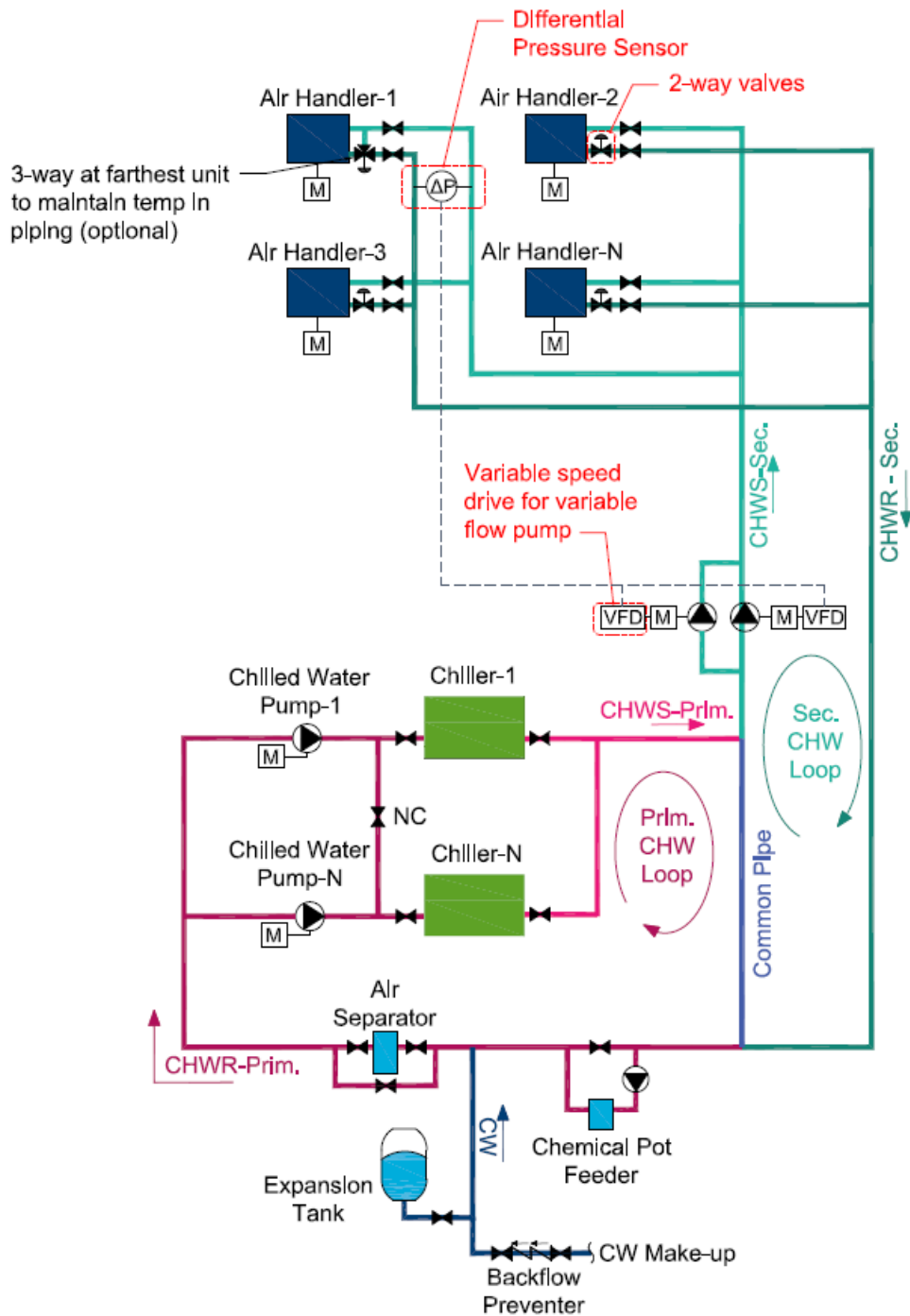

Figure 27: Primary-secondary chilled water distribution schematic. The condenser loop is not shown.

3.5.5 DIRECT-RETURN VS. REVERSE-RETURN

Direct-Return: A direct-return chilled water system supplies and returns chilled water in the most direct path, where the first air handling unit to receive and return chilled water is closest to

The next figure shows the characteristic length for ceiling slot diffusers. For these diffusers the characteristic length is measured to the wall or to the mid-plane between outlets.

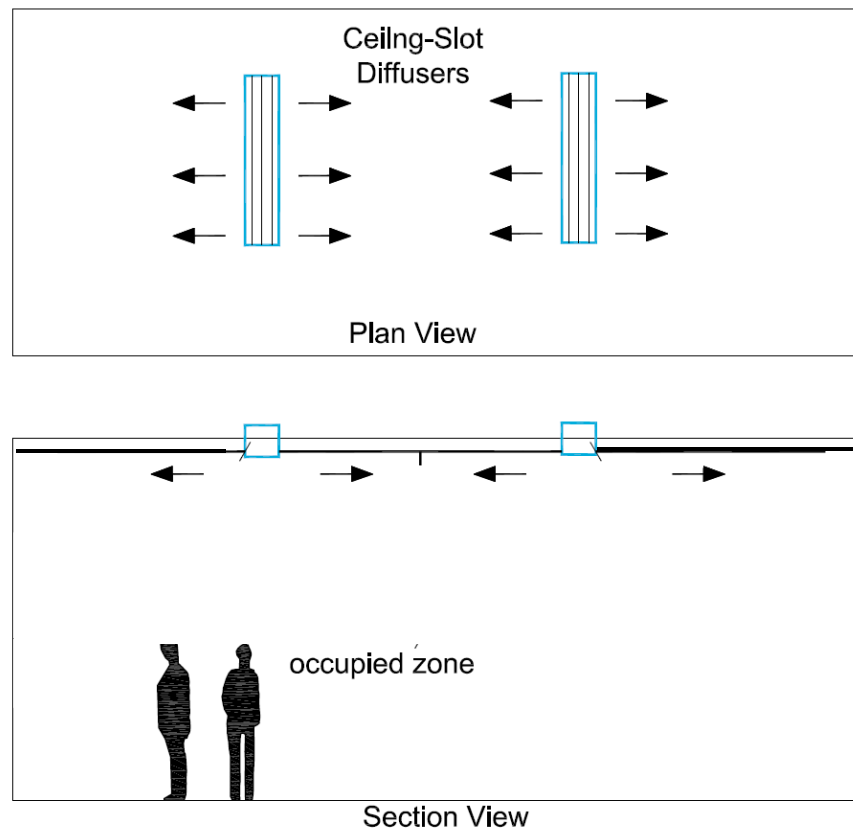

Figure 5: The characteristic length for ceiling slot diffusers is measured from the diffuser to the breathing zone.

2.5 DUCT DESIGN

The best resource for ducting can be found in *ASHRAE Fundamentals*, Chapter 21 Duct Design. The key concepts and skills are presented in the previous discussion, but there may be some random look-up type problems on the PE exam that require you to use your references. You should be familiar with converting between round and rectangular ducts and converting between round and oval ducts or at the very least know where to look for these equations.

2.5.1 CONSTANT VOLUME SYSTEM

There are two major categories of air distribution systems, constant air volume and variable air volume. In a constant volume airflow system, the fan at the air handling unit or fan coil unit is either on or off. Manual balancing dampers are adjusted to supply a set airflow rate through the diffuser based on maximum design conditions. This system has minimal controls and is intended to serve only one temperature zone.

7.0 PRACTICE PROBLEMS

7.1 PROBLEM 1 – DUCT DESIGN

Background: The pressure at the outlet of a 2,000 CFM fan is 0.75 in. wg. The fan discharges into a 12" x 18" duct. The duct runs for an equivalent length of 125' to a supply diffuser. What is the pressure at the supply diffuser? Assume standard conditions, density = 0.075 lbm/ft³ and roughness factor of 0.003 ft. Friction factor = 0.018.

- (a) 0.62 in. wg
- (b) 0.53 in. wg
- (c) 0.41 in. wg
- (d) 0.25 in. wg

7.2 PROBLEM 2 – DUCT DESIGN

Background: A 26" X 12" duct is routed through a ceiling. Due to obstructions in the ceiling, the duct must make (4) 90-degree elbow turns. The elbows are mitered and are provided with turning vanes at 1.5" spacing ($C = 0.11$). If the flow rate through the duct is 3,000 CFM, then what is the total pressure loss due to the elbows?

Assume standard conditions, density = 0.075 lbm/ft³ and roughness factor of 0.003 ft.

- (a) 0.06 in. wg
- (b) 0.08 in. wg
- (c) 0.10 in. wg
- (d) 0.11 in. wg



7.3 PROBLEM 3 – DIFFUSERS

Background: A new diffuser is selected with the following performance criteria. At what perpendicular distance from the wall should the diffuser be located so that the velocity at the wall is 50 feet per minute?

Velocity [fpm]	300	400	500	600	700	800
Total Pressure [in. wg]	.024	.034	.047	.061	.078	.096
Flow Rate [CFM]	100	120	140	160	180	200
Throw 150-100-50 [ft.]	1-2-3	1-2-4	2-2-5	2-3-6	2-3-7	3-4-8

Assume the flow rate through the diffuser is 180 CFM.

- (a) 3'
- (b) 5'
- (c) 7'
- (d) 8'

7.4 PROBLEM 4 – ENERGY RECOVERY DEVICE

A cooling coil is used to cool 2,000 CFM of outside air at 87 F DB, 60% relative humidity to 55 F DB/53 F WB. A heat pipe is provided to re-heat the leaving cold supply air with the incoming outside air. The heat pipe is only used to transfer sensible heat. The heat pipe has a sensible **effectiveness** of 25%. What temperature does the heat pipe reheat the supply air, Dry Bulb F?

- (a) 63°F DB
- (b) 71°F DB
- (c) 75°F DB
- (d) 79°F DB

8.4 SOLUTION 4 – ENERGY RECOVERY DEVICE

A cooling coil is used to cool 2,000 CFM of outside air at 87 F DB, 60% relative humidity to 55 F DB/53 F WB. A heat pipe is provided to re-heat the leaving cold supply air with the incoming outside air. The heat pipe is only used to transfer sensible heat. The heat pipe has a sensible **effectiveness** of 25%. What temperature does the heat pipe reheat the supply air, Dry Bulb F?

First calculate the maximum amount of heat transfer, the supply air is re-heated to the outside air temperature.

$$q_{maximum} = 1.08 * CFM_{supply} * (87 - 55 DB)$$

Next set up the equation for the actual amount of heat that is transferred. Similar equation, except replace the 87 (maximum temperature) with the variable “X”.

$$q_{sensible,actual} = 1.08 * CFM_{supply} * (X - 55 DB)$$

Next, set up the **effectiveness** equation for the Heat Pipe.

$$\epsilon_{sensible} = \frac{q_{sensible,actual}}{q_{sensible,max}}$$

Plug in the variables to find “x”. Where the **effectiveness** is 25%

$$0.25 = \frac{1.08 * CFM_{supply} * (X - 55 DB)}{1.08 * CFM_{supply} * (87 - 55 DB)}$$

$$X = 63^{\circ}F DB$$

8.5 SOLUTION 5 – PRESSURE LOSS

A new chilled water pump supplies a flow of 240 GPM at 150 total dynamic head. What is the pressure drop through 200 feet of 4” schedule 40 steel pipe? C = 140.

The quick solution is to use the *NCEES Mechanical Reference Handbook* pressure drop tables in the Fluids section, but make sure you adjust the pressure drop factor with the 0.54 factor in order to convert from C = 100 to a smoother, C = 140.

These tables show that at 240 GPM, 4” Schedule 40 steel pipe:

$$Pressure Loss = 6.0 ft of head per 100' * 0.54 = 3.24$$

The question calls for the pressure drop over 200’, simply multiply the previous result by 2.

$$Total Pressure Loss = 6.4 ft of head$$



This shows that the sound pressure that you measure at a distance “r” away from a piece of equipment will vary by the square of the distance. The A_0 term is a reference area, which is typically 1 square meter or 1 square foot. The reference term is always needed in order to work in the decibel units. This equation is not provided in the handbook, but the main concept that you need to understand is that sound leaves the source in a spherical manner. As the sound leaves, its sound pressure gets diluted as it now must be applied to larger and larger spheres. The sound level is diluted in relationship to the distance squared.

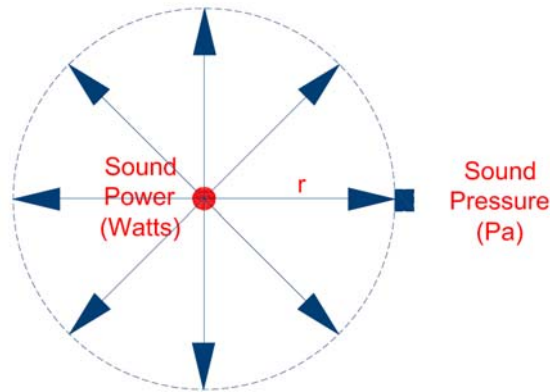

Figure 8: This figure shows a sound source in the center of the sphere. The total amount of sound leaving the source is the sound power. The sound intensity at a certain location at a distance of “r” away from the source can be measured to have a sound pressure in units Pascal.

5.1.4 SOUND FREQUENCY

Sound can be characterized by sinusoidal waveforms. These waveforms will have varying frequencies. For example, a pump that operates at 1,750 revolutions per minute will have a frequency of 29.17 Hz. There will be sound leaving the pump at 29.17 Hz. However, there will be additional sound frequencies because the other pump materials and parts will vibrate at different frequencies.

$$\text{Frequency} = 1,750 \frac{\text{rev}}{\text{min}} * \frac{1 \text{ min}}{60 \text{ s}} = 29.17 \frac{\text{rev}}{\text{s}} = 29.17 \text{ Hz}$$

5.2 INDOOR EQUIPMENT SOUND CALCULATIONS

Equipment produces sound not at just one frequency. The manufacturer of the equipment will produce sound tables, which provides sound levels at a range of frequencies. A sample equipment sound performance data is shown below.

Sound Performance Data								
Frequency [HZ]	63	125	250	500	1,000	2,000	4,000	8,000

8.0 SOLUTIONS

8.1 SOLUTION 1 – DUCT DESIGN

First calculate the equivalent diameter.

$$D_e = \frac{1.30 * (a * b)^{0.625}}{(a + b)^{0.250}} = \frac{1.30 * (12" * 18")^{0.625}}{(12" + 18")^{0.250}}$$

$$D_e = 16" = 1.33 \text{ ft}$$

Next, find the velocity, Reynolds number, followed by the relative roughness and finally the friction factor.

$$V = \frac{2000 \frac{\text{ft}^3}{\text{min}}}{0.25 * \pi(1.33^2)} = 1,432 \text{ fpm} = 23.87 \text{ ft/s}$$

$$Re = \left(23.87 \frac{\text{ft}}{\text{s}}\right) * 1.33 \text{ ft} / 15.8 \times 10^{-5} \text{ ft}^2/\text{s} = 201,461$$

$$\frac{\varepsilon}{D} = \frac{0.003}{1.33} = 0.0022$$

$$f = 0.018$$

Finally, use the Darcy Equation from the HVAC section to find the pressure drop.

$$h_f = f \frac{L}{D} * \rho \left(\frac{V}{1097}\right)^2 = 0.018 * \frac{125 \text{ ft}}{1.33 \text{ ft}} * (0.075) * \left(\frac{1432}{1097}\right)^2 = 0.22$$

$$\text{Pressure at Diffuser} = 0.75 - 0.22 = \mathbf{0.53 \text{ in. wg}}$$

8.2 SOLUTION 2 – DUCT DESIGN

Background: A 26" x 12" duct is routed through a ceiling. Due to obstructions in the ceiling, the duct must make (4) 90-degree elbow turns. The elbows are mitered and are provided with turning vanes at 1.5" spacing (C = 0.11). If the flow rate through the duct is 3,000 CFM, then what is the total pressure loss due to the elbows?

First calculate the equivalent diameter of the duct:

$$D_e = \frac{1.30 * (a * b)^{0.625}}{(a + b)^{0.250}}$$

$$D_e = \frac{1.30 * (12" * 26")^{0.625}}{(12" + 26")^{0.250}}$$



F. Energy/Mass Balance (4-6)

- Steam quality $x = \frac{h-h_f}{h_g-h_f}$
- Steam quality by mass $x = \frac{m_{vapor}}{m_{vapor}+m_{liquid}}$

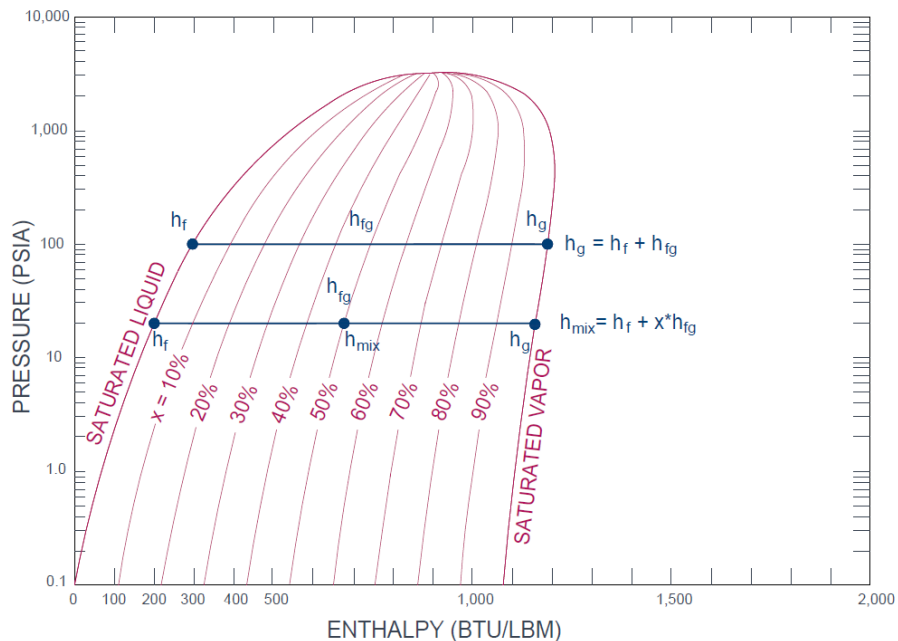

II. Applications (42-64)

A. Heating/Cooling Loads (7-11)

- *Contact Factor* $= \frac{T_{entering} - T_{leaving}}{T_{entering} - T_{apparatus\ dew\ point}}$, how much of the air hits and is cooled by the coil.
- *Bypass Factor* $= 1 - \text{Contact Factor}$, how much air goes around the coil.
- Apparatus Dew Point = Coil Temperature
- Cooling load:
 - Lights, people, miscellaneous equipment; (adjust with usage factors)
 - Envelope
 - Walls/Roof use CLTD
 - Windows use conductive + solar
- Heating loads do not take credit from the heat gain in the space or solar loads.

$$Q_{heating\ load, total} = Q_{wall, conduction} + Q_{roof, conduction} + Q_{window, conduction} + Q_{skylight, conduction} + Q_{infiltration} + Q_{ventilation}$$

- Wall/Roof: No time lag-CLTD; $Q_{heating} = UA\Delta T$
- Window: Conduction only; $Q_{heating} = UA\Delta T$
- Ventilation/Infiltration
- No miscellaneous, people, lights

- VFD: reduce flow by reducing frequency, which reduces RPM and the power of the motor. RPM changes so pump curve changes, parallel to the old curve.

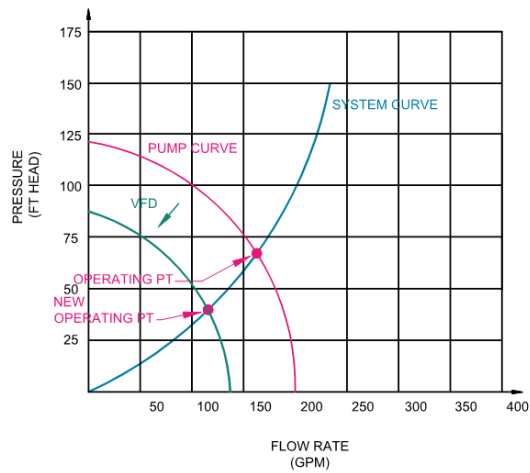

- Power
 - Mechanical HP (Fan) = $\frac{CFM * TP(in\ wg)}{6356}$
 - Mechanical HP (Pump) = $\frac{GPM * TDH(ft)}{3956}$
- Pressure
 - Total Pressure = Static Pressure + Velocity Pressure
 - Velocity Pressure Fan (in wg) = $(FPM/4005)^2$
 - Velocity Pressure Pump (ft hd) = $V^2/(2g)$
- Efficiencies
 - Brake HP = $\frac{Mechanical\ HP}{\eta_{mech}\%}$
 - Electrical HP = $\frac{Brake\ HP}{\eta_{motor}\%} = \frac{Mechanical\ HP}{\eta_{motor}\% * \eta_{mech}\%}$
- Net Positive Suction Head
 - NPSHA (available): Calculated from System
 - Open System: $NPSHA = P_{abs} \pm P_{elev} - P_{fric} - P_{vapor}$
 - Closed System: $NPSHA = P_{gauge} + P_{velocity} - P_{vapor}$
 - NPSHR (required): From Pump Manufacturer
- Compressor: Hermetic – Fully Sealed, Semi Hermitic

6. Cooling/heating coils

- Contact Factor = $\frac{T_{entering} - T_{leaving}}{T_{entering} - T_{apparatus\ dew\ point}}$, how much of the air hits and is cooled by the coil.
- Bypass Factor = 1 – Contact Factor, how much air goes around the coil.
- Apparatus Dew Point = Coil Temperature

7. Control systems components (e.g., valves, dampers)

- Actuators to control opening/closing
- Valves